

**PSWF 1500 N+ Thermal Store**



Main features	
Application	storage and subsequent distribution of thermal energy from solid-fuel boilers, heat pumps or other heat sources; the tank is fitted with a solar heat exchanger and a flanged opening that permits installation of a DHW tube heat exchanger or connecting a solar thermal system
Description	welded steel tank
Working fluid	water, water-glycol mixture (max. 1:1), water-glycerine mixture (max. 2:1), thermal oil
Code	
Thermal Store	<b>15 234</b>
Insulation	<b>16 369</b>
Energy Efficiency Data (as per EC Regulation No. 812/2013)	
	<b>PSWF 1500 N+ with insulation</b>
Energy efficiency class	N/A
Standing loss	171 W
Storage volume	1476 l
Technical Data	
Total tank volume	1498 l
Fluid volume in tank	1476 l
Fluid volume in heat exchanger	22 l
Heat exchanger surface area	4,0 m <sup>2</sup>
Max. working temperature in Thermal Store	95 °C
Max. working temperature in HE	110 °C
Max. working pressure in Thermal Store	3 bar
Max. working pressure in HE	10 bar
Materials	
Tank material	S235JR
Solar heat exchanger material	S235JR+N
Tank perimeter insulation	fleece
Tank perimeter insulation's outer surface	PU leather
Top and bottom tank insulation	fleece
Dimensions, Tipping height, Insulation thickness, Weight	
Tank diameter	1100 mm
Tank diameter with insulation	1300 mm
Tank overall height	1885 mm
Tipping height without insulation	1965 mm
Tank perimeter insulation thickness	100 mm
Bottom insulation thickness	50 mm
Top insulation thickness	120 mm
Empty weight without insulation	265 kg
Accessories	
El. heating element (models)	ETT-A,C, D, F, G, L, M
Heating elem. max. length / output	955 mm / 12 kW
Blind flange	code 6230
Flange for heat exchanger	code 6 231 / 6 232
Tube heat exchanger	max surface area 4,5 m <sup>2</sup>

**PSWF 1500 N+ Thermal Store**

**Dimensions**

Tipping height without insulation 1965 mm.

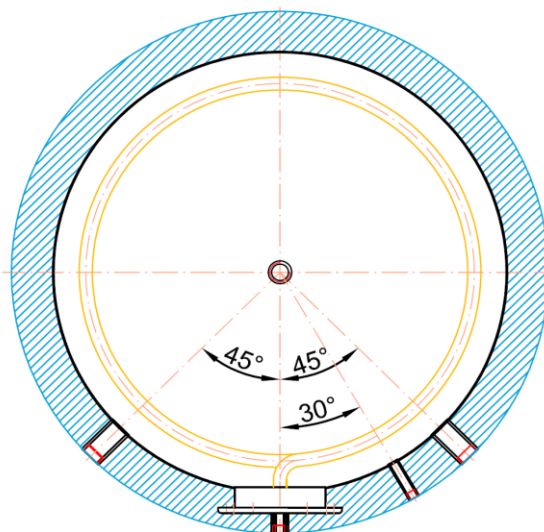
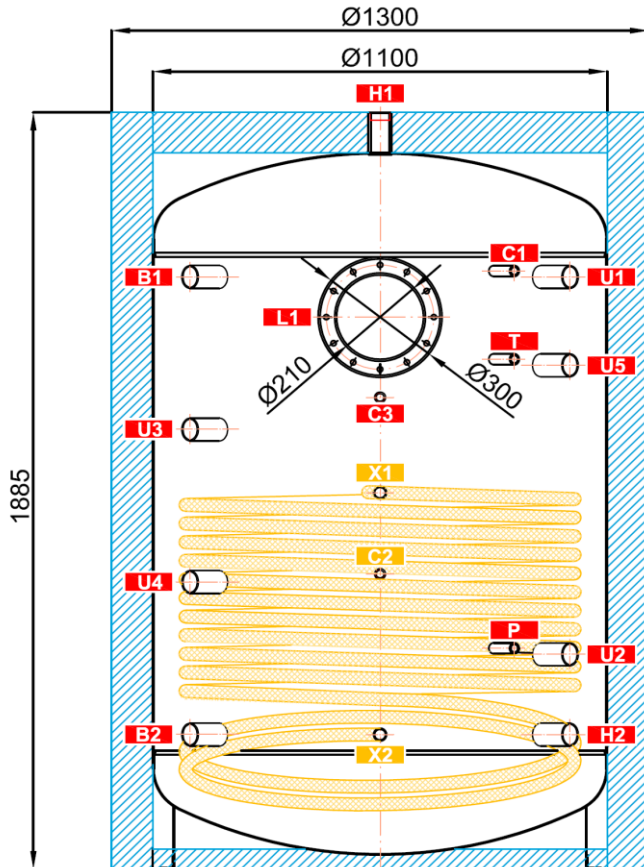

**TAPPINGS**

pos.	connection	height [mm]
<b>Heat sources</b>		
B1	G 6/4" F	1475
B2	G 6/4" F	335
<b>Heating system</b>		
H1	G 6/4" F	1885
H2	G 6/4" F	335
<b>Control and safety</b>		
C1	G 1/2" F	1490
C2	G 1/2" F	735
C3	G 1/2" F	1270
T	G 1/2" F	1175
P	G 1/2" F	550
<b>Universal inlet/outlet</b>		
U1	G 6/4" F	1475
U2	G 6/4" F	535
U3	G 6/4" F	1095
U4	G 6/4" F	715
U5	G 6/4" F	1255
<b>Solar thermal systems</b>		
X1	G 1" F	940
X2	G 1" F	335

**PSWF 1500 N+ Thermal Store**

Heat exchanger pressure drop graph

