



reventon
INDUSTRIAL SOLUTIONS

Technical documentation

UNHEATED AIR CURTAIN

MODELS:

AERIS 100C-1P
AERIS 150C-1P
AERIS 200C-1P



- 1. INTRODUCTION
 - 1.1 PRECAUTIONS
 - 1.2 TRANSPORT
 - 1.3 PACKAGE CONTENT
 - 1.4 USE
- 2. DEVICE CHARACTERISTICS
 - 2.1 DIMENSIONS
 - 2.2 TECHNICAL DATA
- 3. INSTALLATION
 - 3.1 GENERAL PRINCIPLES
 - 3.2 ASSEMBLY „STEP BY STEP”
- 4. INSTALLATION INSTRUCTIONS
 - 4.1 CONNECTION OF THE DEVICE TO THE ELECTRICAL SYSTEM
- 5. PRECAUTIONS AND WARNINGS
- 6. CONTROL
- 7. CONNECTION SCHEMES
- 8. TERMS OF WARRANTY

1. INTRODUCTION

Thank you for purchasing air curtain AERIS. We would like to congratulate on good choice. Please read and save these instructions.

1.1 PRECAUTIONS

The buyer and the user of the device should read carefully the following instructions and proceed to the content recommendations. Proceeding due to the following instruction guarantees the correct usage and safety. In case of any doubts please contact Reventon Group sp. z o. o. [Ltd.]. The supplier reserves the rights to make changes to the technical documentation without previous notice. Reventon Group sp. z o. o. [Ltd.] is not responsible for the damages which occur due to improper installation, not keeping the device in repair or using the device out of line. The installation should be carried out by the professional installers, who possess the qualifications to install these types of devices. The installers are responsible for making the installation as instructed in the technical data. Regulations and safety rules must be followed. During the installation, use, service and periodical inspections all regulations and safety rules must be followed. In case of unserviceable please plug out the device and contact with the authorized person or the supplier. All safety requirements must be taken into account during installation, use or inspection.

1.2 TRANSPORT

During the acceptance of goods it is needed to check the device in order to exclude any damages. During the transport it is needed to use the proper equipment, it is necessary to carry the device by two people. In case of any damages please fill in the damage report in presence of the supplier or the carrier.

1.3 PACKAGE CONTENT

- unheated air curtain
- operation and maintenance manual and warranty card
- assembly panel
- door sensor
- remote controller

1.4 USE

Unheated air curtains (without heat exchanger) are widely installed at the entrances of supermarkets, theaters, meeting rooms, hotels, offices, storages etc. They can reduce penetration of insects, outside dust, unconditioned air into a conditioned space by forcing an air stream over the entire entrance. In winter they prevent uncontrolled heat loss and in summer they prevent heat from the room. However, air curtains should not be used in corrosive environments for aluminum, copper and steel as well as in highly dusty environments (above 0.3 g/m³). The devices should also not be installed in rooms where they would be exposed to high humidity or direct contact with water.

2. DEVICE CHARACTERISTICS

2.1 DIMENSIONS

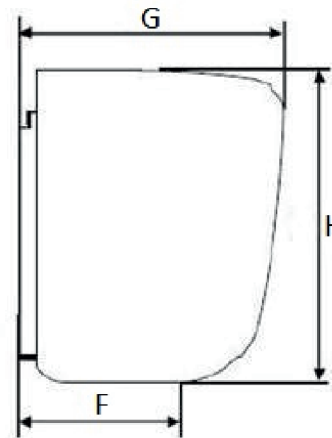
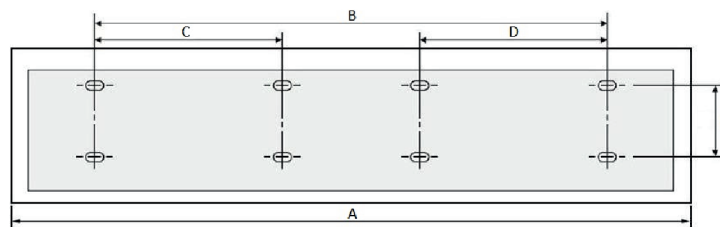

MODEL	A	B	C	D	E	F	G	H	NW (KG)
REVENTON GROUP AERIS 100C-1P	1000	440	---	---	90	132	218	247	13.5
REVENTON GROUP AERIS 150C-1P	1500	440	---	---					18.0
REVENTON GROUP AERIS 200C-1P	2000	660	330	330					25.0

2.2 TECHNICAL DATA

TECHNICAL DATA Product code		AERIS 100C-1P AC100C1P	AERIS 150C-1P AC150C1P	AERIS 200C-1P AC200C1P
Maximum airflow [m ³ /h]	II STAGE	1770	3150	3540
	I STAGE	1450	2550	2900
Maximum air speed [m/s]	II STAGE	11	11	11
	I STAGE	9	9	9
Curtain's range [m]	II STAGE	3	3	3
Supply voltage [V] / Supply frequency [Hz]		230/50	230/50	230/50
Motor power [W]	II STAGE	180	230	360
	I STAGE	130	180	260
Rated motor current [A]	II STAGE	0.78	1.00	1.57
	I STAGE	0.57	0.78	1.13
Class of isolation / Protection degree IP [-]		E / IP 20	E / IP 20	E / IP 20
Net weight [kg]		13.5	18.0	25.0
Noise [dB]	II STAGE	56	57	58
	I STAGE	54	55	56

3. INSTALLATION

3.1. GENERAL PRINCIPLES

The following figures show minimum distances between the air curtain and the building partition:

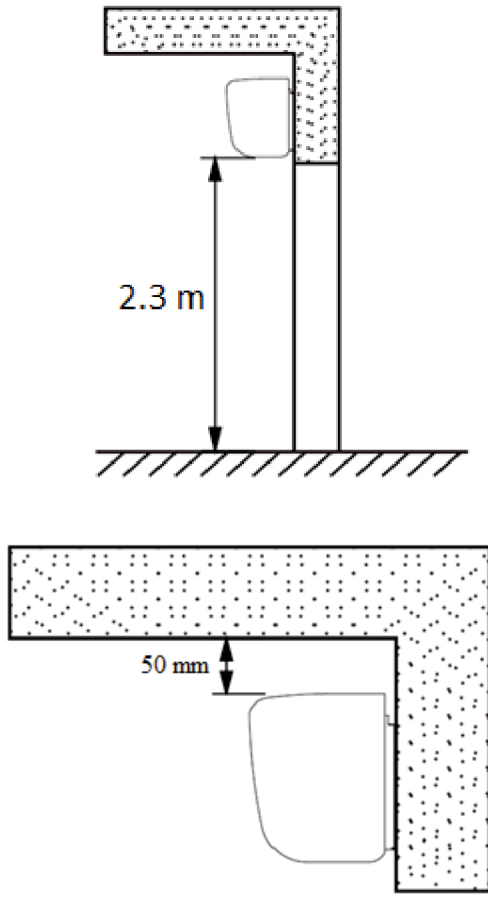

The width of the curtain should be greater or equal to the width of the door frame. When the entrance is wider than the unit, it is recommended to install two or more units in parallel. In this case, provide 10-40 mm gaps between the units.

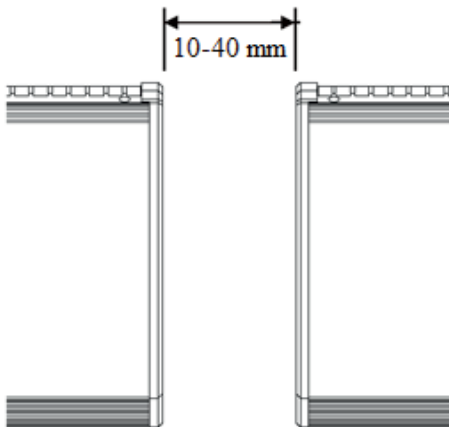

3.2. ASSEMBLY "STEP BY STEP"

The curtain can be assembled on wall or ceiling. If any components are not included in the kit, you should buy them yourself and make sure they are suitable for this type of installation.

a) wall mounting

- unscrew the fixing screws to remove the mounting plate from the back of the main body

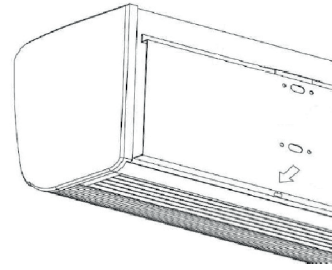

- install mounting plate on the wall

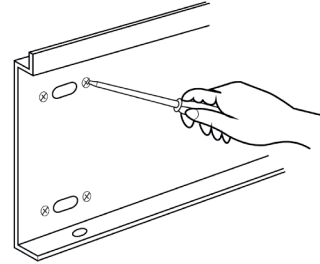

- install the main body. Set the main body onto the upper end of the mounting plate and clamp it as shown

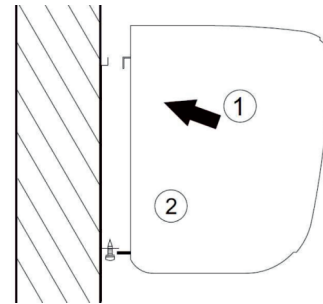

4. INSTALLATION INSTRUCTIONS

4.1. CONNECTION OF THE DEVICE TO THE ELECTRICAL SYSTEM

- all works concerning electrical installation should be made by the qualified personnel (who possess required authorizations to install electrical equipment)
- plug should be put in an appropriate socket and if required, connect the door switch according to wiring diagram (see point 7)
- the electrical installation of the building shall have a residual current device
- check the electrical installation before the first start

5. PRECAUTIONS AND WARNINGS

During operation of the device, the following must be respected:

- all works concerning electrical installation (disassembly, repair etc.) should be made by the qualified personnel, who possess the qualifications due to the domestic and local norms, regarding electrical installations
- do not limit or cover the inlet and outlet of the device
- do not install, service the device with wet hands or barefoot
- the device should be kept out of reach of children and animals
- after the turn off, the elements of device may be warm
- after operating time of the device, please utilize it concerning the local norms and regulations

- don't allow water or any liquid to enter the motor

- maintenance and repair work must be carried out by a qualified personnel familiar with local regulations and standards

- always unplug or disconnect the appliance from the power supply before installation, servicing or cleaning the unit

- never use petrol, benzene, thinners or any other chemicals for cleaning the unit

- periodic maintenance work should be carried out at least once a year by:

- cleaning of plastic parts with water with the addition of soap
- cleaning the casing with a soft cloth

- failure to comply with cleaning obligations may have a negative effect on technical parameters of the device and lead to loss of warranty

- if the device is not used for a longer time disconnect the voltage supply

- if any abnormality happens, turn off the product immediately and check the problem

6. CONTROL

The curtain can be controlled by the remote controller or control panel, located on the housing with three buttons ON/OFF, L and H:

- ON/OFF button allows to turn on/off the device
- L button enables to choose I motor stage (low speed)
- H button is used to switch the motor speed to high one (II stage)

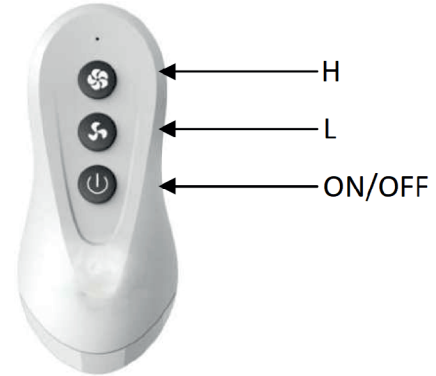

NOTES

- the curtain make a sound 'beep' everytime when you press any button (signaling the command acceptance)

7. CONNECTION SCHEMES

LEGEND:

1. Electric socket
2. Plug
3. Unheated air curtain AERISC-1P
4. Door switch

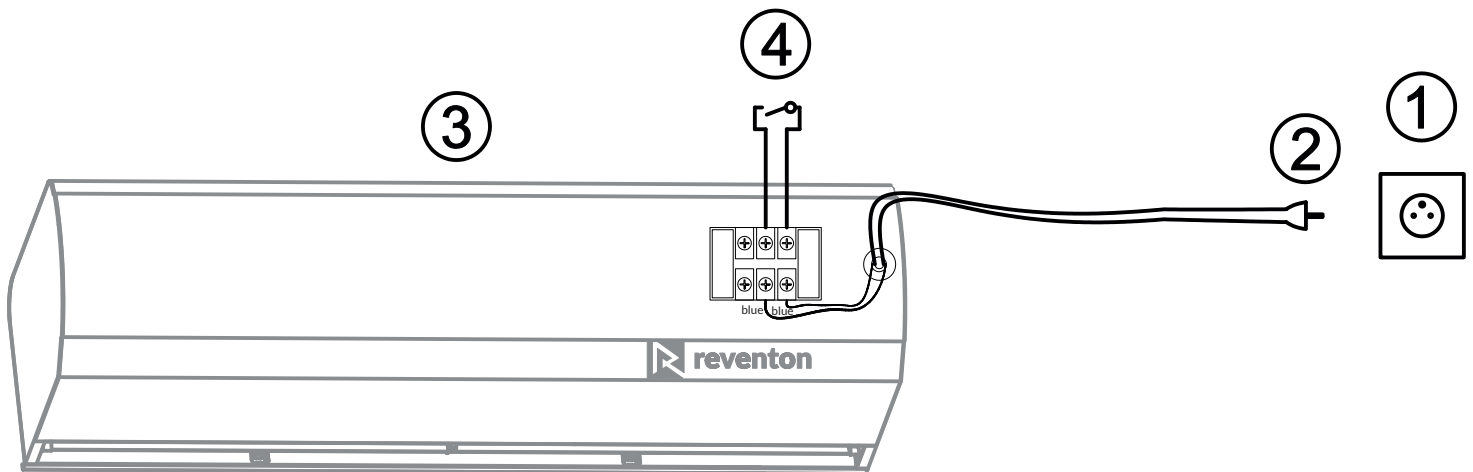

8. TERMS OF WARRANTY

I. Supplier Reventon Group Sp. z o.o. [Ltd.] grants the buyer a 24-month warranty period for the following devices:

- unheated air curtain AERIS 100C-1P
- unheated air curtain AERIS 150C-1P
- unheated air curtain AERIS 200C-1P

II. The terms of warranty are valid from purchasing the device (i.e. invoice / another confirming document issue date) but not longer than 30 months from leaving the supplier's warehouse.

III. To obtain the service it is needed to provide or send to the supplier scans of the warranty card with stamp of installation company, document confirming the purchase (eg. like copy of the invoice) and correctly filled the warranty form.

IV. The supplier is committed to consider the claim within 14 working days since the date of reporting (i.e. day when documents given in point III are provided).

V. In the exceptional cases, the supplier reserves the right to extend the time limit for examination of warranty, especially if the defect is not permanent and its determination requires a longer period of time. The extension must be notified by the supplier before the end of the 14th working day.

VI. Under the guarantee the supplier provides a repairment, replacement or refund for the defective device within a specified time limit.

VII. Warranty does not cover the parts of the device subject to normal maintenance and the following cases:

a) mechanical damage of the product

b) defects and damages through:

- improper storage or transport
- improper or non-compliant use and maintenance (i. e. inconsistent with the manual)
- using the device in the improper conditions (too high humidity, too high or too low temperature, impact of the surrounding, sun etc.)
- unauthorized (by the user or other unauthorized persons) repairs, modifications or construction changes
- connecting equipment inconsistent with the technical documentation
- connecting additional equipment, which is not recommended by the supplier
- improper power supply

c) elements which wear and tear such as discolor of the housing

If there is any of the above, claimant will be charged for transport and / or repairs.

VIII. Any changes in the Warranty Terms, improper use of the product (careless handling, exposure to liquids, moisture, corrosion), as well as traces of selfrepairing (non by the Reventon Group) or alterations cause, the warranty is not valid.

IX. Not following to any of warranty regulations makes the warranty not valid.

X. All correspondence, returns, complains should be send to the following address: Reventon Group Sp. z o.o. [Ltd.], 556 Wyzwolenia Street, 43-340 Kozy, Poland or email address: serwis@reventongroup.eu.

The supplier reserves the rights to make changes to the technical documentation without previous notice.

Warranty card

Factory number of the device:	Address and place of assembly:
Stamp and signature of the installation company:	

Warranty form

The company reporting the complaint:	Date of assembly:	Address and place of assembly the device:
The company installing the device:	Date and circumstances of noticing the defect:	
	Factory number of the device:	Date of declaration the complaint:
Description of the defect:		
Contact Name and Surname, telephone number/ e-mail address:		

Service card

Date of declaration the complaint:	Description of the repair:	Service stamp:
Date of repair:		



reventon
INDUSTRIAL SOLUTIONS

Reventon Group Sp. z o.o. [Ltd.], 556 Wyzwolenia Street, 43-340 Kozy, Poland, www.reventongroup.eu