



reventon
INDUSTRIAL SOLUTIONS

Technical documentation

WATER HEATED AIR CURTAIN

MODELS:

AERIS 100WN-1P
AERIS 150WN-1P
AERIS 200WN-1P



EN

1. INTRODUCTION

- 1.1 PRECAUTIONS
- 1.2 TRANSPORT
- 1.3 PACKAGE CONTENT
- 1.4 USE

2. DEVICE CHARACTERISTICS

- 2.1 DIMENSIONS
- 2.2 TECHNICAL DATA

3. INSTALLATION

- 3.1 GENERAL PRINCIPLES
- 3.2 ASSEMBLY „STEP BY STEP”

4. INSTALLATION INSTRUCTIONS

- 4.1 CONNECTION OF THE DEVICE TO THE HYDAULIC SYSTEM
- 4.2 CONNECTION OF THE DEIVCE TO THE ELECTRICAL SYSTEM

5. PRECAUTIONS AND WARNINGS

- 6. CONTROLS
- 7. CONNECTION SCHEMES
- 8. TERMS OF WARRANTY

1. INTRODUCTION

Thank you for purchasing air curtain AERIS. We would like to congratulate on good choice. Please read and save these instructions.

1.1 PRECAUTIONS

The buyer and the user of the device should read carefully the following instructions and proceed to the content recommendations. Proceeding due to the following instruction guarantees the correct usage and safety. In case of any doubts please contact Reventon Group sp. z o. o. [Ltd.]. The supplier reserves the rights to make changes to the technical documentation without previous notice. Reventon Group sp. z o. o. [Ltd.] is not responsible for the damages which occur due to improper installation, not keeping the device in repair or using the device out of line. The installation should be carried out by the professional installers, who possess the qualifications to install these types of devices. The installers are responsible for making the installation as instructed in the technical data. Regulations and safety rules must be followed. During the installation, use, service and periodical inspections all regulations and safety rules must be followed. In case of unserviceable please plug out the device and contact with the authorized person or the supplier. All safety requirements must be taken into account during installation, use or inspection.

1.2 TRANSPORT

During the acceptance of goods it is needed to check the device in order to exclude any damages. During the transport it is needed to use the proper equipment, it is necessary to carry the device by two people. In case of any damages please fill in the damage report in presence of the supplier or the carrier.

1.3 PACKAGE CONTENT

- air curtain
- operation and maintenance manual and warranty card
- assembly panel
- door sensor

1.4 USE

Air curtains are widely installed at the entrances of supermarkets, theaters, meeting rooms, hotels, offices, storages etc. They can reduce penetration of insects, outside dust, unconditioned air into a conditioned space by forcing an air stream over the entire entrance. In winter they prevent uncontrolled heat loss and in summer they prevent heat from the room. However, air curtains should not be used in corrosive environments for aluminum, copper and steel as well as in highly dusty environments (above 0.3 g/m³). The devices should also not be installed in rooms where they would be exposed to high humidity or direct contact with water.

2. DEVICE CHARACTERISTICS

2.1 DIMENSIONS

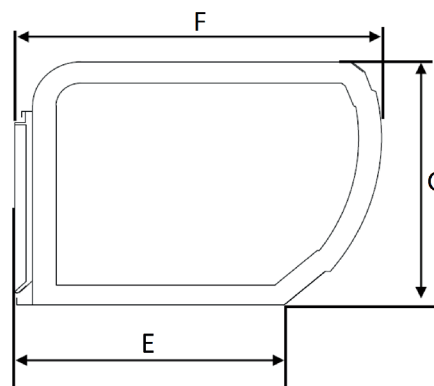
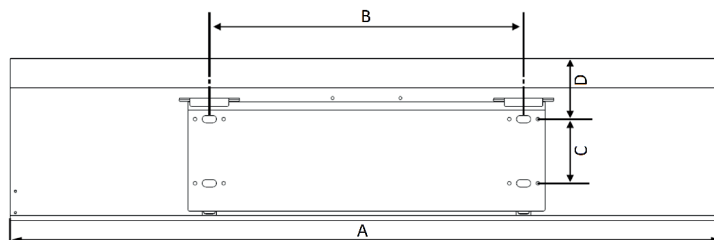

MODEL	A	B	C	D	E	F	G	N.W (KG)
REVENTON GROUP AERIS 100WN-1P	1000	440						18
REVENTON GROUP AERIS 150WN-1P	1500	840	90	83	228	310	227	28
REVENTON GROUP AERIS 200WN-1P	2000							34

2.2. TECHNICAL DATA

TECHNICAL DATA Product code		AERIS 100WN-1P AC100WN1P	AERIS 150WN-1P AC150WN1P	AERIS 200WN-1P AC200WN1P
Power of the device [kW]*	III BIEG	17.0	26.1	37.1
	II BIEG	15.8	24.1	34.0
	I BIEG	14.2	21.9	31.4
Maximum airflow [m³/h]	III BIEG	1500	2250	3250
	II BIEG	1350	2000	2850
	I BIEG	1150	1750	2550
Maximum air speed [m/s]	III BIEG	9	9	9
	II BIEG	8	8	8
	I BIEG	7	7	7
Curtain's range [m]	III BIEG	3	3	3
Water flow rate [dm³/h]	III BIEG	749	1150	1638
	II BIEG	698	1062	1498
	I BIEG	625	968	1386
Maximum water temperature [°C]		90	90	90
Maximum pressure [MPa]		1.6	1.6	1.6
Connection diameter ["]		¾	¾	¾
Supply voltage [V] / Supply frequency [Hz]		230/50	230/50	230/50
Rated motor current [A]	III BIEG	0.65	0.87	1.39
	II BIEG	0.57	0.78	1.30
	I BIEG	0.52	0.70	1.22
Motor power [W]	III BIEG	150	200	320
	II BIEG	130	180	300
	I BIEG	120	160	280
Class of isolation / Protection degree IP [-]		E / IP 20	E / IP 20	E / IP 20
Net weight [kg]		18	28	34
Noise [dB]	III BIEG	57	59	61
	II BIEG	55	57	59
	I BIEG	52	54	56

* according to parameters: water 90/70 °C and inlet air temperature 0°C

TECHNICAL PARAMETERS HEATING

Model: REVENTON AERIS 100WN-1P	AIR FLOW														
	III STAGE = 9m/s					II STAGE = 8m/s					I STAGE = 7m/s				
	V=1500 m3/h					V=1350 m3/h					V=1150 m3/h				
	T _{p1}	P _T	Q _w	ΔP _w	T _{p2}	T _{p1}	P _T	Q _w	ΔP _w	T _{p2}	T _{p1}	P _T	Q _w	ΔP _w	T _{p2}
	°C	kW	l/h	kPa	°C	°C	kW	l/h	kPa	°C	°C	kW	l/h	kPa	°C
Tw1/Tw2 = 90/70°C	0	17.0	749	21.3	36.0	0	15.8	698	18.8	37.5	0	14.2	625	15.4	40.0
	5	15.9	703	19.0	38.5	5	14.8	655	16.7	40.0	5	13.3	587	13.7	42.5
	10	14.9	655	16.7	41.0	10	13.8	611	14.7	42.5	10	12.4	547	12.1	45.0
	15	13.8	608	14.6	44.0	15	12.8	566	12.9	45.0	15	11.5	507	10.5	47.0
	20	12.7	560	12.6	46.5	20	11.8	522	11.1	47.5	20	10.6	467	9.1	49.5
Tw1/Tw2 = 80/60°C	0	14.6	643	16.7	31.0	0	13.6	599	14.7	32.5	0	12.2	537	12.0	34.5
	5	13.6	596	14.5	33.5	5	12.7	556	12.8	35.0	5	11.3	498	10.5	37.0
	10	12.5	549	12.5	36.5	10	11.6	512	11.0	37.5	10	10.4	458	9.1	39.5
	15	11.4	501	10.6	39.0	15	10.6	467	9.4	40.0	15	9.5	418	7.7	41.5
	20	10.3	453	8.9	41.5	20	9.6	422	7.8	42.5	20	8.6	378	6.4	44.0
Tw1/Tw2 = 70/50°C	0	12.3	538	12.5	26.0	0	11.5	501	11.0	27.0	0	10.3	449	9.0	29.0
	5	11.2	491	10.6	28.5	5	10.5	457	9.3	29.5	5	9.4	410	7.7	31.5
	10	10.1	443	8.8	31.5	10	9.4	413	7.8	32.0	10	8.5	370	6.4	33.5
	15	9.0	395	7.2	34.0	15	8.4	368	6.3	35.0	15	7.5	330	5.2	36.0
	20	7.9	346	5.7	36.5	20	7.4	323	5.0	37.5	20	6.6	289	4.1	38.5
Tw1/Tw2 = 60/40°C	0	9.9	432	8.8	21.0	0	9.3	403	7.8	22.0	0	8.3	361	6.4	23.5
	5	8.8	385	7.1	23.5	5	8.2	359	6.3	24.5	5	7.4	322	5.2	26.0
	10	7.7	337	5.6	26.5	10	7.2	314	5.0	27.0	10	6.5	282	4.1	28.0
	15	6.6	288	4.3	29.0	15	6.2	269	3.8	29.5	15	5.5	241	3.1	30.5
	20	5.5	238	3.1	31.5	20	5.1	222	2.7	32.0	20	4.6	199	2.2	32.5

V – air volume
P_T – heating capacity
T_{p1} – inlet air temperature
T_{p2} – outlet air temperature
T_{w1} – inlet water temperature
T_{w2} – outlet water temperature
Q_w – water flow rate
ΔP_w – pressure drop of water

Model: REVENTON AERIS 150WN-1P	AIR FLOW														
	III STAGE = 9m/s					II STAGE = 8m/s					I STAGE = 7m/s				
	V=2250 m3/h					V=2000 m3/h					V=1750 m3/h				
	T _{p1}	P _T	Q _w	ΔP _w	T _{p2}	T _{p1}	P _T	Q _w	ΔP _w	T _{p2}	T _{p1}	P _T	Q _w	ΔP _w	T _{p2}
°C	kW	l/h	kPa	°C	°C	kW	l/h	kPa	°C	°C	kW	l/h	kPa	°C	
Tw1/Tw2 = 90/70°C	0	26.1	1150	22.7	36.5	0	24.1	1062	19.6	38.5	0	21.9	968	16.6	40.5
	5	24.4	1078	20.2	39.5	5	22.6	996	17.5	41.0	5	20.6	908	14.8	43.0
	10	22.8	1006	17.8	42.0	10	21.1	930	15.4	43.5	10	19.2	847	13.0	45.5
	15	21.1	933	15.5	44.5	15	19.5	862	13.4	46.0	15	17.8	786	11.4	47.5
	20	19.5	860	13.4	47.0	20	18.0	794	11.6	48.5	20	16.4	724	9.8	50.0
Tw1/Tw2 = 80/60°C	0	22.5	988	17.7	31.5	0	20.8	912	15.3	33.0	0	18.9	832	13.0	35.0
	5	20.8	916	15.4	34.5	5	19.3	846	13.4	35.5	5	17.6	772	11.3	37.5
	10	19.2	843	13.3	37.0	10	17.7	779	11.5	38.0	10	16.2	710	9.8	40.0
	15	17.5	770	11.3	39.5	15	16.2	712	9.8	40.5	15	14.8	649	8.3	42.0
	20	15.8	696	9.4	42.0	20	14.6	643	8.2	43.0	20	13.4	587	6.9	44.5
Tw1/Tw2 = 70/50°C	0	18.9	826	13.2	26.5	0	17.5	764	11.5	28.0	0	15.9	696	9.7	29.5
	5	17.2	754	11.2	29.0	5	15.9	697	9.8	30.5	5	14.5	636	8.3	32.0
	10	15.6	681	9.4	32.0	10	14.4	630	8.1	33.0	10	13.1	574	6.9	34.0
	15	13.9	608	7.6	34.5	15	12.8	562	6.6	35.5	15	11.7	512	5.6	36.5
	20	12.2	533	6.0	37.0	20	11.3	493	5.2	38.0	20	10.3	449	4.5	39.0
Tw1/Tw2 = 60/40°C	0	15.3	666	9.3	21.5	0	14.1	615	8.1	22.5	0	12.9	561	6.9	24.0
	5	13.6	593	7.6	24.0	5	12.6	548	6.6	25.0	5	11.5	500	5.6	26.0
	10	11.9	519	6.0	26.5	10	11.0	480	5.2	27.5	10	10.0	438	4.4	28.5
	15	10.2	445	4.5	29.5	15	9.4	411	4.0	30.0	15	8.6	375	3.4	31.0
	20	8.5	368	3.3	32.0	20	7.8	341	2.8	32.5	20	7.1	311	2.4	33.0

V – air volume
P_T – heating capacity
T_{p1} – inlet air temperature
T_{p2} – outlet air temperature
T_{w1} – inlet water temperature
T_{w2} – outlet water temperature
Q_w – water flow rate
ΔP_w – pressure drop of water

Model: REVENTON AERIS 200WN-1P	AIR FLOW														
	III STAGE = 9m/s					II STAGE = 8m/s					I STAGE = 7m/s				
	V=3250 m3/h					V=2850 m3/h					V=2550 m3/h				
	T _{p1}	P _T	Q _w	ΔP _w	T _{p2}	T _{p1}	P _T	Q _w	ΔP _w	T _{p2}	T _{p1}	P _T	Q _w	ΔP _w	T _{p2}
°C	kW	l/h	kPa	°C	°C	kW	l/h	kPa	°C	°C	kW	l/h	kPa	°C	
Tw1/Tw2 = 90/70°C	0	37.1	1638	53.5	36.5	0	34.0	1498	45.4	38.5	0	31.4	1386	39.4	40.5
	5	34.8	1538	47.6	39.5	5	31.9	1406	40.5	41.0	5	29.5	1301	35.1	43.0
	10	32.5	1436	42.0	42.0	10	29.8	1313	35.7	43.5	10	27.5	1215	31.0	45.0
	15	30.2	1333	36.7	44.5	15	27.6	1219	31.2	46.0	15	25.6	1128	27.1	47.5
	20	27.9	1229	31.7	47.0	20	25.5	1125	26.9	48.5	20	23.6	1040	23.4	50.0
Tw1/Tw2 = 80/60°C	0	32.1	1411	41.9	31.5	0	29.4	1290	35.6	33.5	0	27.2	1194	30.9	35.0
	5	29.8	1310	36.6	34.5	5	27.3	1198	31.1	36.0	5	25.2	1108	27.0	37.5
	10	27.5	1207	31.6	37.0	10	25.1	1105	26.9	38.5	10	23.3	1022	23.3	40.0
	15	25.1	1104	26.8	39.5	15	23.0	1010	22.9	41.0	15	21.3	935	19.9	42.0
	20	22.8	1000	22.4	42.0	20	20.8	915	19.1	43.5	20	19.3	847	16.6	44.5
Tw1/Tw2 = 70/50°C	0	27.1	1185	31.5	26.5	0	24.8	1084	26.8	28.0	0	22.9	1003	23.3	29.5
	5	24.8	1084	26.8	29.5	5	22.7	991	22.8	30.5	5	21.0	917	19.8	32.0
	10	22.4	981	22.4	32.0	10	20.5	897	19.1	33.0	10	19.0	830	16.6	34.5
	15	20.0	877	18.2	34.5	15	18.3	802	15.6	35.5	15	17.0	743	13.6	36.5
	20	17.6	772	14.6	37.0	20	16.1	706	12.4	38.0	20	14.9	654	10.8	39.0
Tw1/Tw2 = 60/40°C	0	22.0	961	22.4	22.0	0	20.2	879	19.1	23.0	0	18.7	813	16.6	24.0
	5	19.7	859	18.3	24.5	5	18.0	786	15.6	25.5	5	16.7	727	13.6	26.5
	10	17.3	755	14.5	27.0	10	15.9	691	12.4	28.0	10	14.7	639	10.8	29.0
	15	14.9	650	11.1	29.5	15	13.6	595	9.5	30.5	15	12.6	550	8.3	31.0
	20	12.5	543	8.1	32.0	20	11.4	497	6.9	33.0	20	10.6	460	6.0	33.5

V – air volume
P_T – heating capacity
T_{p1} – inlet air temperature
T_{p2} – outlet air temperature
T_{w1} – inlet water temperature
T_{w2} – outlet water temperature
Q_w – water flow rate
ΔP_w – pressure drop of water

3. INSTALLATION

3.1. GENERAL PRINCIPLES

The following figures show minimum distances between the air curtain and the building partition:

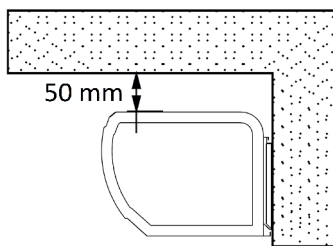
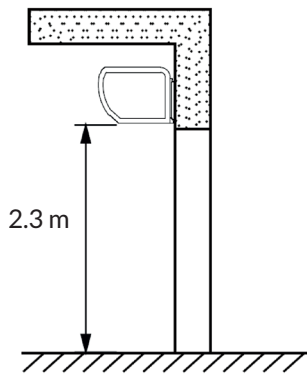

The width of the curtain should be greater or equal to the width of the door frame. When the entrance is wider than the unit, it is recommended to install two or more units in parallel. In this case, provide 10-40 mm gaps between the units

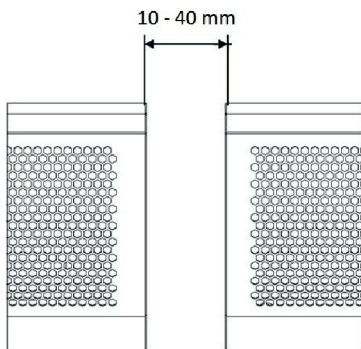

3.2. ASSEMBLY "STEP BY STEP"

The curtain can be assembled on wall or ceiling. If any components are not included in the kit, you should buy them yourself and make sure they are suitable for this type of installation.

a) wall mounting

- unscrew the fixing screws to remove the mounting plate from the back of the main body

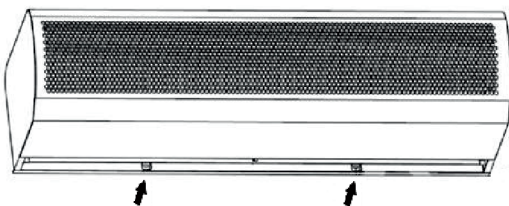

-install mounting plate on the wall

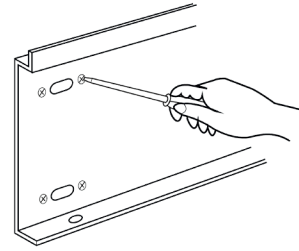

-install the main body. Set the main body onto the upper end of the mounting plate and clamp it as shown

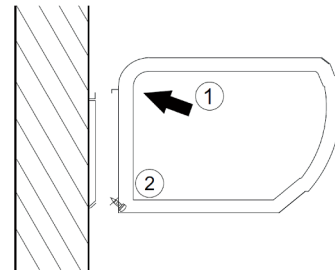

b) ceiling mounting (using mounting studs)

-screw the mounting studs into four threaded holes (for min 20 mm)

-install the unit using mounting studs to the ceiling

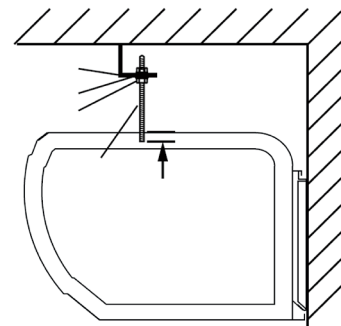

4. INSTALLATION INSTRUCTIONS

4.1. CONNECTION OF THE DEVICE TO THE HYDAULIC SYSTEM

- pipes should be connected like on the figure below (water supply form the front, water return from the back)

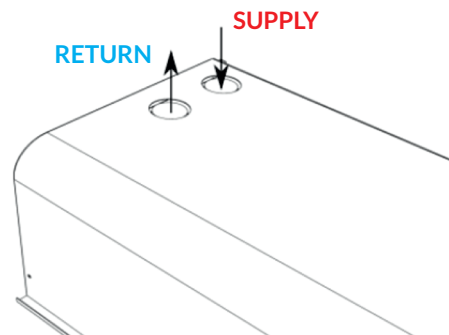

- it is recommended to use a filter on the curtain's hydraulic power supply

- it is recommended to use the following valves:

- vent valve in the highest place on the hydraulic installation
- cut off valve on the supply and return of the device

- the installation shall be protected against excessive pressure increase

- check the leak tightness of the hydraulic system before connecting the unit before plugging the electric supply

4.2. CONNECTION OF THE DEVICE TO THE ELECTRICAL SYSTEM

- all works concerning electrical installation should be made by the qualified personnel (who possess required authorizations to install electrical equipment), based on wiring schematic diagrams. (see 7)

- the electrical installation of the building shall have a residual current device

- check the electrical installation and automation before the first start

5. PRECAUTIONS AND WARNINGS

During operation of the device, the following must be respected:

- all works concerning electrical installation (disassembly, repair etc.) should be made by the qualified personnel, who possess the qualifications due to the domestic and local norms, regarding electrical installations

- do not limit or cover the inlet and outlet of the device

- do not install, service the device with wet hands or barefoot

- the device should be kept out of reach of children and animals

- when no need heating, turn off the heat source to use it as an unheated air curtain

- the device does not consist of the anti-frost protection. The temperature in the room, where device is installed, should not go below 0°C. If such situation could take place empty the device out of water

- after the turn off, the elements of device may be warm

- after operating time of the device, please utilize it concerning the local norms and regulations

- don't allow water or any liquid to enter the motor

- maintenance and repair work must be carried out by a qualified personnel familiar with local regulations and standards

- always unplug or disconnect the appliance from the power supply before installation, servicing or cleaning the unit

- never use petrol, benzene, thinners or any other chemicals for cleaning the unit

- periodic maintenance work should be carried out at least once a year by:

- cleaning the heat exchanger and other elements from dust
- cleaning of plastic parts with water with the addition of soap
- cleaning the casing with a soft cloth

- failure to comply with cleaning obligations may have a negative effect on technical parameters of the device and lead to loss of warranty

- the flow of the heating medium through the heat exchanger must be dependent on the fan operation (e.g. using a thermostatic valve) - it is forbidden to keep the flow without the fan motor running

- if the device is not used for a longer time disconnect the voltage supply

- if any abnormality happens, turn off the product immediately and check the problem

6. CONTROLS

Usage of automatic control dedicated to the air water heaters of Reventon Group gives great possibilities of adjusting the efficiency of the curtain in different, depending on needs, degree of automation of its operation. We also offer additional controls:

3-stage speed regulator with thermostat HC-3S

is used to regulate devices equipped with 3-stage fans. It has a 3-stage speed control and built-in thermostat switches the device of automatically when the preset temperature is reached. In addition, the unit controls the operation of the actuators installed on the control valve.



Voltage/Frequency: 230 V AC / 50 - 60 Hz
Maximum current output: 3 A
Temperature range: 10°C - 30°C
Operating mode: ciągły lub termostatyczny
Control accuracy: < 1°C
Dimensions: 130 x 85 x 40 mm
Weight: 210 g
Degree of casing's protection: IP 30

Programmable controller HMI

is used to regulate devices equipped with 3-stage fans. It is an advanced controller with many functions i. a. operation in heating, cooling or mixed mode, programmable mode, valve control, automatic selection of the fan speed. Together with the controller an external sensor is provided, which allows to read the temperature in the required place, even remote from the controller. In addition, the device can be integrated with the BMS building control system (using the MODBUS communication protocol).



Voltage/ Frequency: 230 V AC / 50 - 60 Hz
Maximum current: 5 A
Operating temperature range: 0 - 45°C
Regulation range: 5°C - 35°C
Regulation accuracy: ± 0.5°C
External temperature sensor: NTC 10K
Communication: RS485
Dimensions: 86 x 86 x 13.3 mm 270 g
Degree of protection (housing): IP 20
Degree of protection (external sensor): IP 68

Two-way valve with actuator HC 3/4"

is used to automatically regulate the flow of the heating medium.

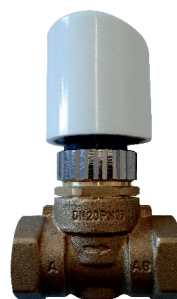

Voltage / Frequency: 230 V AC / 50 - 60 Hz
Power consumption: 2 VA
Kvs coefficient: 6.3 m³/h
Stroke: 3 mm
Operating condition of actuator: -5°C - 60°C
Running time: 3 - 5 min
Degree of protection: IP 54

Three-way valve with actuator HC 3/4"

is used to automatically regulate the flow of the heating medium.



Power supply/ Frequency: 230 V AC / 50 - 60 Hz
Power consumption: 7 VA
Kvs coefficient: 6.5 m³/h
Operating condition of actuator: 0 - 60°C
Running time (motor): 18 s
Running time (return spring): 5 s
Degree of protection: IP 20

7. CONNECTION SCHEMES

LEGEND:

1. Power
2. Main switch, overcurrent circuit breaker*
3. Water heated air curtain AERISWN-1P
4. 3-stage speed controllers with thermostat HC3S
 - A-work in continuous mode
 - B-operation in thermostatic mode
5. Two-way valve with actuator HC ¾"
6. Door switch
7. Programmable controller HMI
8. External temperature sensor
9. Controller HMI CURTAIN

*Main switch and overcurrent circuit breaker are not included in the device

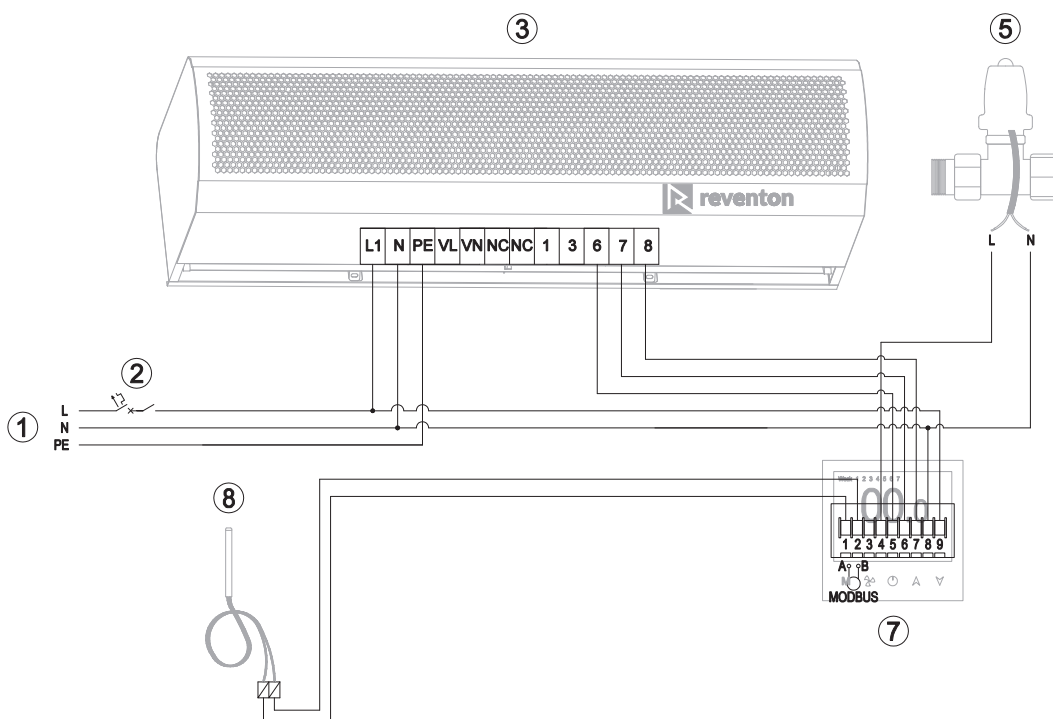
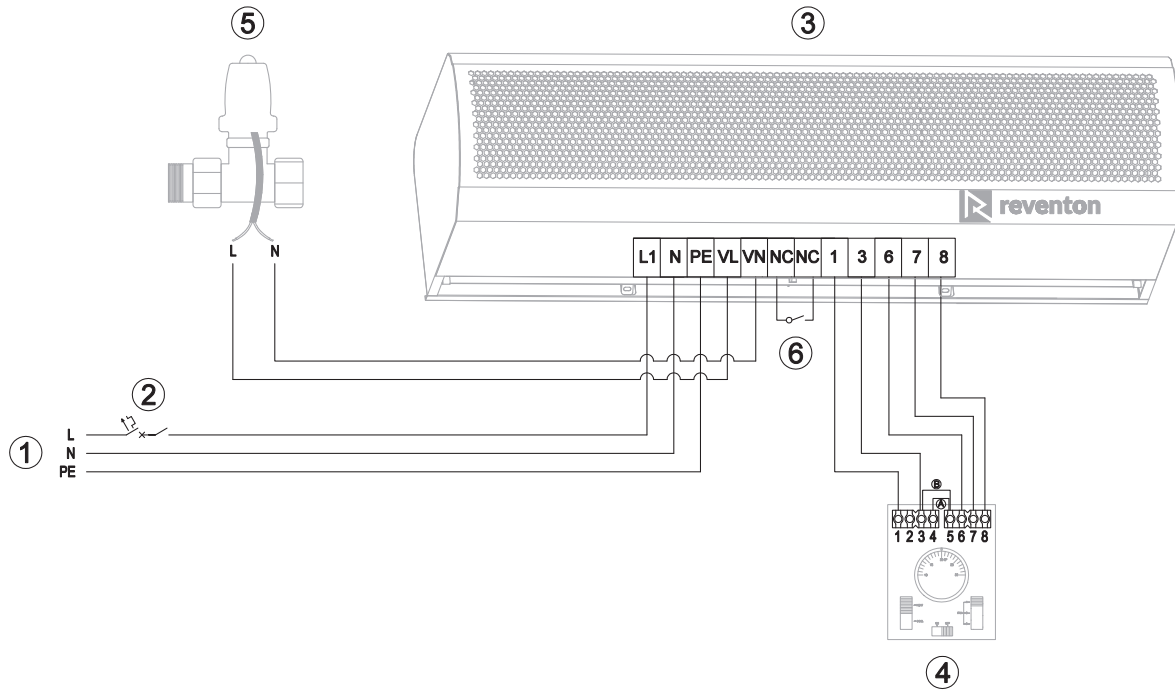

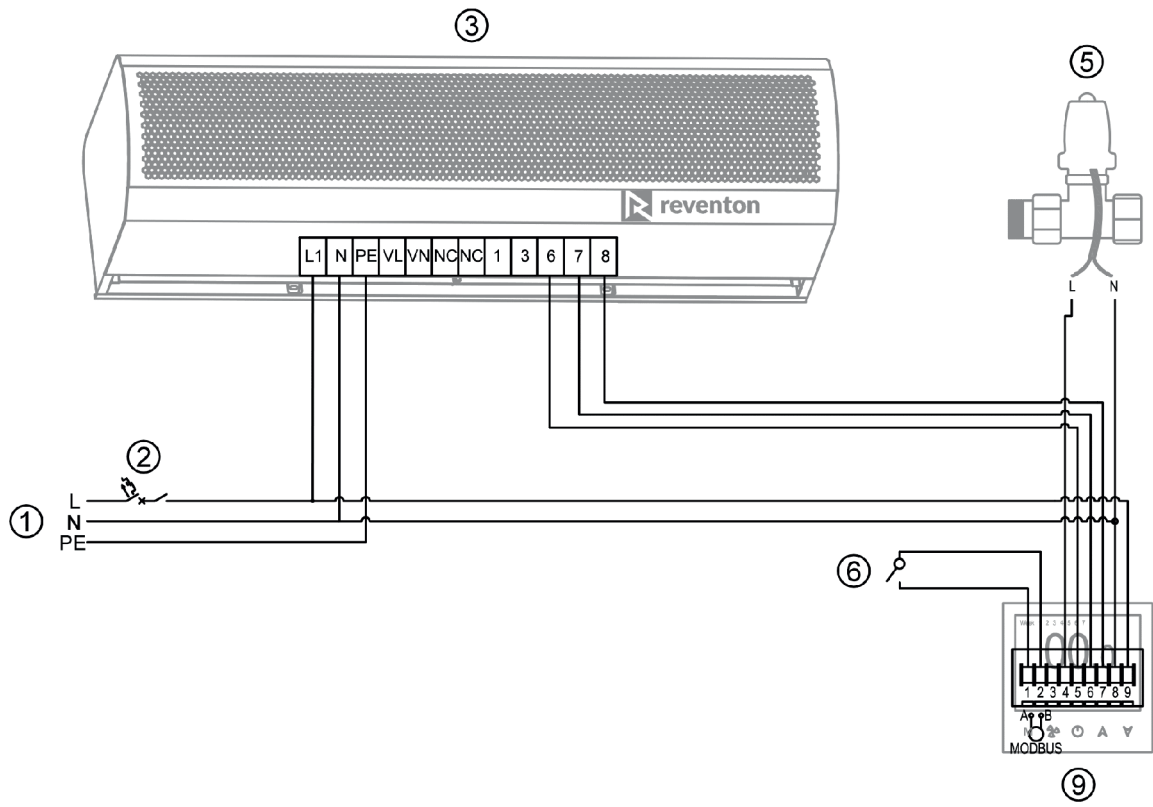

8. TERMS OF WARRANTY

I. Supplier Reventon Group Sp. z o.o. [Ltd.] grants the buyer a 24-month warranty period for the following devices:

- water heated air curtain AERIS 100WN-1P
- water heated air curtain AERIS 150WN-1P
- water heated air curtain AERIS 200WN-1P

II. The terms of warranty are valid from purchasing the device (i.e. invoice / another confirming document issue date) but not longer than 30 months from leaving the supplier's warehouse.

III. To obtain the service it is needed to provide or send to the supplier scans of the warranty card with stamp of installation company, document confirming the purchase (eg. like copy of the invoice) and correctly filled the warranty form.

IV. The supplier is committed to consider the claim within 14 working days since the date of reporting (i.e. day when documents given in point III are provided).

V. In the exceptional cases, the supplier reserves the right to extend the time limit for examination of warranty, especially if the defect is not permanent and its determination requires a longer period of time. The extension must be notified by the supplier before the end of the 14th working day.

VI. Under the guarantee the supplier provides a repairment, replacement or refund for the defective device within a specified time limit.

VII. Warranty does not cover the parts of the device subject to normal maintenance and the following cases:

a) mechanical damage of the product

b) defects and damages through:

- improper storage or transport
- improper or non-compliant use and maintenance (i. e. inconsistent with the manual)
- using the device in the improper conditions (too high humidity, too high or too low temperature, impact of the surrounding, sun etc.)
- unauthorized (by the user or other unauthorized persons) repairs, modifications or construction changes
- connecting equipment inconsistent with the technical documentation
- connecting additional equipment, which is not recommended by the supplier
- improper power supply

c) elements which wear and tear such as discolor of the housing

If there is any of the above, claimant will be charged for transport and / or repairs.

VIII. Any changes in the Warranty Terms, improper use of the product (careless handling, exposure to liquids, moisture, corrosion), as well as traces of selfrepairing (non by the Reventon Group) or alterations cause, the warranty is not valid.

IX. Not following to any of warranty regulations makes the warranty not valid.

X. All correspondence, returns, complains should be send to the following address: Reventon Group Sp. z o.o. [Ltd.], 556 Wyzwolenia Street, 43-340 Kozy, Poland or email address: serwis@reventongroup.eu.

The supplier reserves the rights to make changes to the technical documentation without previous notice.

Warranty card

Factory number of the device:	Address and place of assembly:
Stamp and signature of the installation company:	

Warranty form

The company reporting the complaint:	Date of assembly:	Address and place of assembly the device:
The company installing the device:	Date and circumstances of noticing the defect:	
	Factory number of the device:	Date of declaration the complaint:
Description of the defect:		
Contact Name and Surname, telephone number/ e-mail address:		

Service card

Date of declaration the complaint:	Description of the repair:	Service stamp:
Date of repair:		



reventon
INDUSTRIAL SOLUTIONS

Reventon Group Sp. z o.o. [Ltd.], 556 Wyzwolenia Street, 43-340 Kozy, Poland, www.reventongroup.eu