



reventon
INDUSTRIAL SOLUTIONS

Technical documentation

AIR WATER HEATERS IN STEEL CASING S-3S SERIES

MODELS:

S1-3S
S2-3S
S3-3S
S4-3S



1. INTRODUCTION

- 1.1 PRECAUTIONS
- 1.2 TRANSPORT
- 1.3 PACKAGE CONTENT
- 1.4 USE

2. DEVICE CHARACTERISTICS

- 2.1 CONSTRUCTION AND PRINCIPLE OF OPERATION
- 2.2 DEVICE DIMENSIONS
- 2.3 DEVICE TECHNICAL DATA

3. ASSEMBLY

- 3.1 GENERAL PRINCIPLES
- 3.2 ROTATING MOUNTING BRACKET
- 3.3 FIXED HOLDERS

4. INSTALLATION INSTRUCTIONS

- 4.1 CONNECTION OF THE DEVICE TO THE HYDAULIC SYSTEM
- 4.2 CONNECTION OF THE DEIVCE TO THE ELECTRICAL SYSTEM

5. PRECAUTIONS & WARNINGS

- 6. CONTROLS
- 7. CONNECTION SCHEMES
- 8. TERMS OF WARRANTY

1. INTRODUCTION

Thank you very much for purchasing air water heater S-3S. We would like to congratulate you on excellent choice. Please read and keep this manual.

1.1 PRECAUTIONS

The buyer and the user of the air water heater Reventon Group brand should read carefully the following instructions and proceed to the content recommendations. Proceeding due to the following instruction guarantees the correct usage and safety. In case of any doubts please contact directly Reventon Group sp. z o. o. [Ltd.]. The producer reserves the rights to make changes to the technical documentation without previous notice. Reventon Group sp. z o. o. [Ltd.] is not responsible for the damages which occur due to improper installation, not keeping the device in repair or using the device out of line. The installation should be carried out by the professional installers, who possess the qualifications to install these types of devices. The installers are responsible for making the installation as instructed in the technical data. In case of unserviceable please plug out the device and contact with the authorized for repair person or the supplier. During the installation, use, service and periodical inspections all regulations and safety rules must be followed.

1.2 TRANSPORT

During the acceptance of goods, it is needed to check the device to exclude any damages. During the transport, it is needed to use the proper equipment, it is necessary to carry the device by two people. In case of any damages please fill in the damage report in presence of the supplier.

1.3 PACKAGE CONTENT

- heater
- operation and maintenance manual and warranty card

1.4 USE

Heating devices Reventon Group S series are used to heat spaces such as: production halls, warehouses, commercial room, service spaces, garages, workshops, greenhouses, tents, shops, malls, shopping malls etc. However, heating devices should not be used in corrosive environments for aluminum, copper and steel as well as in highly dusty environments (above 0.3 g/m³). The devices should not be installed in rooms where they would be exposed to high humidity or direct contact with water.

2. DEVICE CHARACTERISTICS

2.1 CONSTRUCTION AND PRINCIPLE OF OPERATION

Casing: made of galvanized steel casing, powder painted in RAL 9005 color.

Air stators: made of galvanized steel casing, powder painted in RAL 7048 color. It is possible to adjust manually the air stators to achieve the needed direction of the air flow.

Heating coil: made of copper and aluminum. Supplied by distribution working fluid, which circulates through the coil and releases heat to the air. The coil has the following technical parameters: the maximum temperature of the heating factor is 120°C; maximum pressure 1.6 MPa; headers diameter ¾". Depending on dimensions of the device the heaters are equipped with 1, 2 or 3-row heating coils.

Axial blowing fan: made of galvanized steel. The objective of the fan is to ensure air flow through the exchanger. It has a single-phase, three speed motor with the following parameters: protection degree IP54, rate current 0.2 - 0.84 A (depending on model and operating mode). Model S1-3S has fan with diameter 300 mm. Models S2-3S and S3-3S have fans with diameter 350 mm and S4-3S has fan with diameter 400 mm.

Rotating mounting bracket (optional equipment): enables the device to be installed in several configurations (depending on the requirements) and the unit to be rotated in a horizontal plane.

Fixed holders (optional equipment): made of steel, element for mounting the device on a wall or ceiling. Solid and durable construction, possible to assemble device in parallel on the angle 60° and 45°.

2.2 DEVICE DIMENSIONS

- S1-3S:

- height (A): 452 mm
- width (B): 494 mm
- depth (C): 305 mm

- S2-3S and S3-3S:

- height (A): 552 mm
- width (B): 545 mm
- depth (C): 368 mm

- S4-3S:

- height (A): 660 mm
- width (B): 696 mm
- depth (C): 384 mm

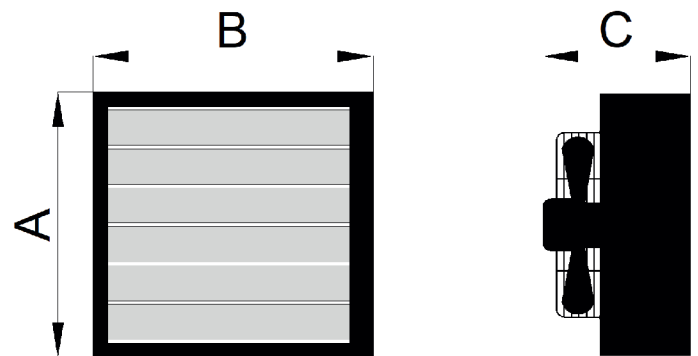

2.3 DEVICE TECHNICAL DATA

TECHNICAL DATA		S1-3S	S2-3S	S3-3S	S4-3S
Product code		WHS1-3S-1789	WHS2-3S-1790	WHS3-3S-1791	WHS4-3S-1787
Nominal heating capacity [kW]*	III STAGE	14.7	23.4	36.9	50.1
	II STAGE	13.1	16.0	20.8	38.5
	I STAGE	11.3	14.0	17.8	27.5
Heating capacity range [kW]**		1.57 – 19.5	2.1-30.8	2.92-48.8	4.17-66.2
Maximum airflow [m ³ /h]	III STAGE	1400	2000	1800	3350
	II STAGE	1150	1100	850	2250
	I STAGE	900	900	700	1400
Maximum horizontal range [m]		10	13	11	18
Number of rows [pcs.]		1	2	3	2
Capacity of water [dm ³]		0.5	1.3	1.9	2
Maximum temperature of working fluid [°C]		120	120	120	120
Maximum working pressure [MPa]		1.6	1.6	1.6	1.6
Connection diameter ["]		3/4	3/4	3/4	3/4
Supply voltage [V] / Supply frequency [Hz]		230/50	230/50	230/50	230/50
Rated motor current [A]	III STAGE	0.40	0.58	0.58	0.84
	II STAGE	0.30	0.30	0.30	0.65
	I STAGE	0.25	0.20	0.20	0.54
Motor speed [rpm]	III STAGE	1350	1400	1400	1400
	II STAGE	1150	1000	1000	1050
	I STAGE	900	680	680	750
Motor power [W]	III STAGE	85	125	125	190
	II STAGE	65	75	75	150
	I STAGE	55	45	45	120
Protection degree IP [-]		54	54	54	54
Net weight [kg]		15	21	23	27
Noise [dB]***	III STAGE	51	54	53	56
	II STAGE	45	48	47	50
	I STAGE	43	46	45	48

* for parameters 90/70°C and 0°C inlet air temperature

** max. 120/90°C, 0°C inlet air temperature, III stage // min. 40/30°C, 20°C inlet air temperature, I stage

*** measurement at a distance of 5 m from the device

Parameters	S1-3S-3 stage 1400 m ³ /h				
Supply/return water temperature [°C]	120/90				
Dry bulb air inlet temperature [°C]	0	5	10	15	20
Heating capacity [kW]	19.5	18.3	17.1	16.0	14.8
Dry bulb air outlet temperature [°C]	38.7	42.0	45.2	48.4	51.6
Water flow [m ³ /h]	0.57	0.54	0.51	0.47	0.44
Pressure drop in the heat exchanger [kPa]	12	11	10	9	7

Parameters	S1-3S-3 stage 1400 m ³ /h				
Supply/return water temperature [°C]	90/70				
Dry bulb air inlet temperature [°C]	0	5	10	15	20
Heating capacity [kW]	14.7	13.6	12.5	11.4	10.3
Dry bulb air outlet temperature [°C]	29.3	32.5	35.7	38.8	42.0
Water flow [m ³ /h]	0.65	0.6	0.55	0.5	0.45
Pressure drop in the heat exchanger [kPa]	16	14	12	10	8

Parameters	S1-3S-3 stage 1400 m ³ /h				
Supply/return water temperature [°C]	80/60				
Dry bulb air inlet temperature [°C]	0	5	10	15	20
Heating capacity [kW]	12.6	11.5	10.4	9.35	8.3
Dry bulb air outlet temperature [°C]	25.1	28.3	31.5	34.6	37.7
Water flow [m ³ /h]	0.55	0.51	0.46	0.41	0.36
Pressure drop in the heat exchanger [kPa]	12	10	9	7	6

Parameters	S1-3S-3 stage 1400 m ³ /h				
Supply/return water temperature [°C]	70/50				
Dry bulb air inlet temperature [°C]	0	5	10	15	20
Heating capacity [kW]	10.5	9.42	8.35	7.3	6.28
Dry bulb air outlet temperature [°C]	20.9	24.1	27.2	30.3	33.4
Water flow [m ³ /h]	0.46	0.41	0.37	0.32	0.27
Pressure drop in the heat exchanger [kPa]	9	7	6	5	4

Parameters	S1-3S-3 stage 1400 m ³ /h				
Supply/return water temperature [°C]	50/30				
Dry bulb air inlet temperature [°C]	0	5	10	15	20
Heating capacity [kW]	6.23	5.2	4.18	3.18	2.19
Dry bulb air outlet temperature [°C]	12.4	15.5	18.6	21.7	24.7
Water flow [m ³ /h]	0.27	0.23	0.18	0.14	0.1
Pressure drop in the heat exchanger [kPa]	4	3	2	1	1

Parameters	S1-3S-3 stage 1400 m ³ /h				
Supply/return water temperature [°C]	40/30				
Dry bulb air inlet temperature [°C]	0	5	10	15	20
Heating capacity [kW]	6.02	4.98	3.97	2.98	2.01
Dry bulb air outlet temperature [°C]	12.0	15.1	18.2	21.3	24.3
Water flow [m ³ /h]	0.52	0.43	0.34	0.26	0.17
Pressure drop in the heat exchanger [kPa]	12	9	6	3	2

Parameters	S2-3S-3 stage 2000 m ³ /h				
Supply/return water temperature [°C]	120/90				
Dry bulb air inlet temperature [°C]	0	5	10	15	20
Heating capacity [kW]	30.8	29.0	27.1	25.3	23.6
Dry bulb air outlet temperature [°C]	42.9	46.0	49.1	52.2	55.2
Water flow [m ³ /h]	0.91	0.86	0.8	0.75	0.7
Pressure drop in the heat exchanger [kPa]	7	6	6	5	4

Parameters	S2-3S-3 stage 2000 m ³ /h				
Supply/return water temperature [°C]	90/70				
Dry bulb air inlet temperature [°C]	0	5	10	15	20
Heating capacity [kW]	23.4	21.6	19.8	18.1	16.5
Dry bulb air outlet temperature [°C]	32.5	35.6	38.6	41.6	44.6
Water flow [m ³ /h]	1.03	0.95	0.87	0.8	0.73
Pressure drop in the heat exchanger [kPa]	9	8	7	6	5

Parameters	S2-3S-3 stage 2000 m ³ /h				
Supply/return water temperature [°C]	80/60				
Dry bulb air inlet temperature [°C]	0	5	10	15	20
Heating capacity [kW]	20.1	18.4	16.7	15.0	13.4
Dry bulb air outlet temperature [°C]	28.0	31.0	34.0	37.0	39.9
Water flow [m ³ /h]	0.88	0.81	0.73	0.66	0.59
Pressure drop in the heat exchanger [kPa]	7	6	5	4	3

Parameters	S2-3S-3 stage 2000 m3/h				
Supply/return water temperature [°C]	70/50				
Dry bulb air inlet temperature [°C]	0	5	10	15	20
Heating capacity [kW]	16.9	15.2	13.5	11.8	10.2
Dry bulb air outlet temperature [°C]	23.4	26.5	29.4	32.4	35.3
Water flow [m³/h]	0.74	0.66	0.59	0.52	0.45
Pressure drop in the heat exchanger [kPa]	5	4	4	3	2

Parameters	S2-3S-3 stage 2000 m3/h				
Supply/return water temperature [°C]	50/30				
Dry bulb air inlet temperature [°C]	0	5	10	15	20
Heating capacity [kW]	10.3	8.63	7.02	5.44	3.84
Dry bulb air outlet temperature [°C]	14.3	17.2	20.1	23.0	25.7
Water flow [m³/h]	0.45	0.37	0.3	0.24	0.17
Pressure drop in the heat exchanger [kPa]	2	2	1	1	0

Parameters	S2-3S-3 stage 2000 m3/h				
Supply/return water temperature [°C]	40/30				
Dry bulb air inlet temperature [°C]	0	5	10	15	20
Heating capacity [kW]	9.69	8.07	6.48	4.92	3.39
Dry bulb air outlet temperature [°C]	13.5	16.4	19.3	22.2	25.1
Water flow [m³/h]	0.84	0.7	0.56	0.43	0.29
Pressure drop in the heat exchanger [kPa]	7	5	4	2	1

Parameters	S3-3S-3 stage 1800 m3/h				
Supply/return water temperature [°C]	120/90				
Dry bulb air inlet temperature [°C]	0	5	10	15	20
Heating capacity [kW]	48.8	45.8	42.9	40.1	37.4
Dry bulb air outlet temperature [°C]	75.4	77.1	78.8	80.4	82.0
Water flow [m³/h]	1.44	1.35	1.27	1.18	1.1
Pressure drop in the heat exchanger [kPa]	15	13	12	11	9

Parameters	S3-3S-3 stage 1800 m3/h				
Supply/return water temperature [°C]	90/70				
Dry bulb air inlet temperature [°C]	0	5	10	15	20
Heating capacity [kW]	36.9	34.1	31.3	28.7	26.1
Dry bulb air outlet temperature [°C]	57.0	58.6	60.2	61.8	63.3
Water flow [m³/h]	1.63	1.5	1.38	1.26	1.15
Pressure drop in the heat exchanger [kPa]	19	17	14	12	10

Parameters	S3-3S-3 stage 1800 m3/h				
Supply/return water temperature [°C]	80/60				
Dry bulb air inlet temperature [°C]	0	5	10	15	20
Heating capacity [kW]	32.0	29.2	26.6	24.0	21.4
Dry bulb air outlet temperature [°C]	49.4	51.0	52.6	54.1	55.5
Water flow [m³/h]	1.4	1.28	1.17	1.05	0.94
Pressure drop in the heat exchanger [kPa]	15	13	11	9	7

Parameters	S3-3S-3 stage 1800 m3/h				
Supply/return water temperature [°C]	70/50				
Dry bulb air inlet temperature [°C]	0	5	10	15	20
Heating capacity [kW]	27.0	24.4	21.7	19.2	16.7
Dry bulb air outlet temperature [°C]	41.8	43.4	44.8	46.3	47.7
Water flow [m³/h]	1.18	1.07	0.95	0.84	0.73
Pressure drop in the heat exchanger [kPa]	11	9	8	6	5

Parameters	S3-3S-3 stage 1800 m3/h				
Supply/return water temperature [°C]	50/30				
Dry bulb air inlet temperature [°C]	0	5	10	15	20
Heating capacity [kW]	17.0	14.4	11.9	9.37	6.82
Dry bulb air outlet temperature [°C]	26.3	27.7	29.0	30.3	31.3
Water flow [m³/h]	0.74	0.63	0.52	0.41	0.3
Pressure drop in the heat exchanger [kPa]	5	4	3	2	1

Parameters	S3-3S-3 stage 1800 m3/h				
Supply/return water temperature [°C]	40/30				
Dry bulb air inlet temperature [°C]	0	5	10	15	20
Heating capacity [kW]	15.5	13.0	10.5	8.13	5.73
Dry bulb air outlet temperature [°C]	24.0	25.5	26.9	28.3	29.5
Water flow [m³/h]	1.35	1.13	0.91	0.7	0.5
Pressure drop in the heat exchanger [kPa]	16	11	8	5	3

Parameters	S4-3S-3 stage 3350 m3/h				
Supply/return water temperature [°C]	120/90				
Dry bulb air inlet temperature [°C]	0	5	10	15	20
Heating capacity [kW]	66.2	62.1	58.2	54.4	50.6
Dry bulb air outlet temperature [°C]	55.0	57.6	60.1	62.6	65.1
Water flow [m³/h]	1.96	1.84	1.72	1.61	1.49
Pressure drop in the heat exchanger [kPa]	17	15	13	12	10

Parameters	S4-3S-3 stage 3350 m3/h				
Supply/return water temperature [°C]	90/70				
Dry bulb air inlet temperature [°C]	0	5	10	15	20
Heating capacity [kW]	50.1	46.2	42.5	38.8	35.2
Dry bulb air outlet temperature [°C]	41.6	44.1	46.6	49.0	51.4
Water flow [m³/h]	2.21	2.04	1.87	1.71	1.55
Pressure drop in the heat exchanger [kPa]	22	19	16	13	11

Parameters	S4-3S-3 stage 3350 m3/h				
Supply/return water temperature [°C]	80/60				
Dry bulb air inlet temperature [°C]	0	5	10	15	20
Heating capacity [kW]	43.1	39.4	35.7	32.1	28.6
Dry bulb air outlet temperature [°C]	35.8	38.3	40.7	43.1	45.5
Water flow [m³/h]	1.9	1.73	1.57	1.41	1.26
Pressure drop in the heat exchanger [kPa]	17	14	12	10	8

Parameters	S4-3S-3 stage 3350 m3/h				
Supply/return water temperature [°C]	70/50				
Dry bulb air inlet temperature [°C]	0	5	10	15	20
Heating capacity [kW]	36.2	32.5	28.9	25.4	21.9
Dry bulb air outlet temperature [°C]	30.0	32.4	34.9	37.2	39.5
Water flow [m³/h]	1.58	1.42	1.26	1.11	0.96
Pressure drop in the heat exchanger [kPa]	12	10	8	6	5

Parameters	S4-3S-3 stage 3350 m3/h				
Supply/return water temperature [°C]	50/30				
Dry bulb air inlet temperature [°C]	0	5	10	15	20
Heating capacity [kW]	22.0	18.5	15.0	11.6	8.19
Dry bulb air outlet temperature [°C]	18.3	20.6	22.9	25.2	27.3
Water flow [m³/h]	0.95	0.8	0.65	0.5	0.36
Pressure drop in the heat exchanger [kPa]	5	4	2	2	1

Parameters	S4-3S-3 stage 3350 m3/h				
Supply/return water temperature [°C]	40/30				
Dry bulb air inlet temperature [°C]	0	5	10	15	20
Heating capacity [kW]	20.7	17.2	13.9	10.5	7.24
Dry bulb air outlet temperature [°C]	17.2	19.6	21.9	24.2	26.4
Water flow [m³/h]	1.8	1.49	1.2	0.91	0.63
Pressure drop in the heat exchanger [kPa]	16	12	8	5	2

3. ASSEMBLY

3.1. GENERAL PRINCIPLES

During installation, ensure a free air flow to the device and do not restrict the air stream supply. The figures below show the recommended distances between the heater and building partitions:

a) in case of wall mounting

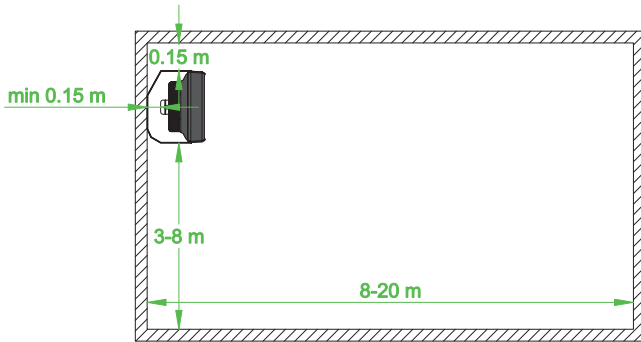

b) in case of ceiling mounting

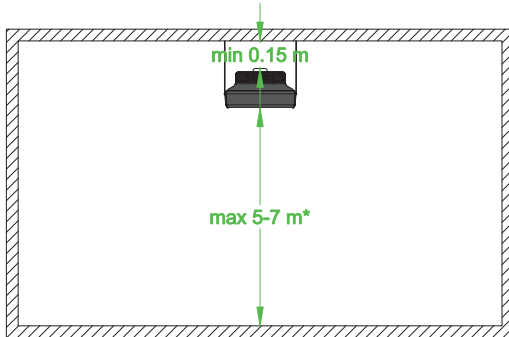

* the maximum vertical range depends on the model

In case of higher heat demand, more units can be installed in the room. In order to ensure proper air flow, it is necessary to maintain the recommended distances between the heaters, as shown in the following figure.

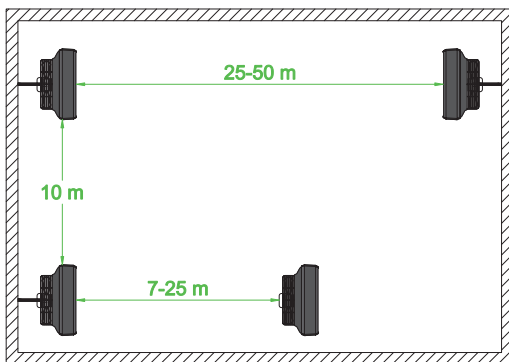

3.2. ROTATING MOUNTING BRACKET

The Reventon Group S series devices can be assembled using a rotating mounting bracket. It enables the heaters installation on the wall or ceiling, depending on the required optimal direction of airflow.

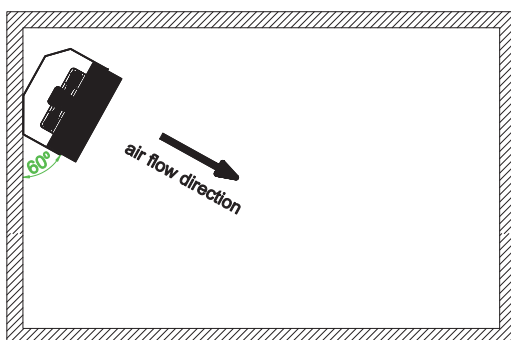

3.3 FIXED HOLDERS

The heater can be mounted on a wall or ceiling with fixed holders. They enable to regulate degree slope in range 15°.

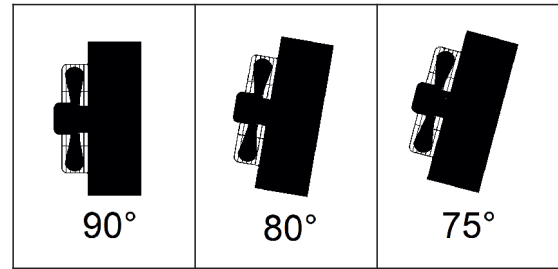

4. INSTALLATION INSTRUCTIONS

4.1. CONNECTION OF THE DEVICE TO THE HYDAULIC SYSTEM

- pipes should be connected as indicated on the heater (supply from below, return from above)

- connecting the device to the hydraulic installation, do remember to hold the connectors by pipes spanner

Not keeping to the recommendation may cause the damages of the heating coil.

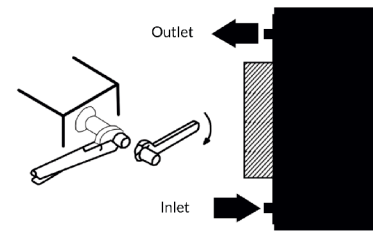

- it is recommended to use filter on the water supply pipe

- it is recommended to use the following valves:

- vent valve in the highest place on the hydraulic installation
- cut off valve on the supply and return pipes of the device

- installation has to be secured against excessive increase of pressure

- it is recommended to check the leak tightness of the hydraulic system before plugging the electric supply

4.2. CONNECTION OF THE DEVICE TO THE ELECTRICAL SYSTEM

- all works concerning electrical installation should be made by the qualified personnel (who possess required authorizations to install electrical equipment), based on wiring schematic diagrams (see 7)

- the electrical installation of the building shall have a residual current device

- it is recommended to check the electric installation and controls before the first start

5. PRECAUTIONS & WARNINGS

The precautions mentioned below must be strictly followed during operation of the device:

- all works concerning electrical installation (disassembly, repair etc.) should be made by the qualified staff, who possess the qualifications due to the domestic and local norms, regarding electrical installations

- before service or exchange of the device it is obligatory to cut off the current supply

- do not limit or cover the inlet and outlet of the device

- do not install, service the device with wet hands or barefoot

- the device should be kept out of reach of children and animals

- the device does not consist of the anti-frost protection; the temperature in the room, where device is installed, should not go below 0°C; if such situation could take place empty the device out of water

- after the turn off, the elements of device may be warm

- after operating time of the device, please utilize it concerning the local norms and regulations

- it is recommended to clean the device periodically (at least twice a year):
 - heating coil blow with compressed air
 - fan casing and blades clean from dirt
- failure to comply with cleaning obligations may have a negative effect on technical parameters of the device and lead to loss of warranty
- if the device is not used for a longer time disconnect the power supply
- the device is transported with the closed air stators. It is essential to open them in at least for 30% before first start
- opening the air stators must be done by two hands in parallel

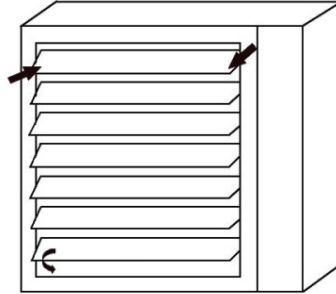

6.CONTROLS

Usage of automatic control dedicated to the air water heaters of Reventon Group gives great possibilities of adjusting the efficiency of the heater in different, depending on needs, degree of its operation automation. We can offer the following:

3-stage speed controller with thermostat HC-35

is used to regulate devices equipped with 3-stage fans. It has a 3-stage speed control and built-in thermostat switches the device of automatically when the preset temperature is reached. In addition, the unit controls the operation of the actuators installed on the control valve.



Voltage/ Frequency: 230 V AC / 50 – 60 Hz
 Maximum current output: 3 A
 Temperature range: 10°C - 30°C
 Operating mode: continuous or thermostatic
 Control accuracy: < 1°C
 Dimensions: 130 x 85 x 40 mm
 Weight: 210 g
 Degree of casing's protection: IP 30

Programmable controller HMI

is used to regulate devices equipped with 3-stage fans. It is an advanced controller with many functions i. a. operation in heating, cooling or mixed mode, programmable mode, valve control, automatic selection of the fan speed. Together with the controller an external sensor is provided, which allows to read the temperature in the required place, even remote from the controller. In addition, the device can be integrated with the BMS building control system (using the MODBUS communication protocol).



Voltage/ Frequency: 230 V AC / 50 – 60 Hz
 Maximum current: 5 A
 Operating temperature range: 0 - 45°C
 Regulation range: 5°C - 35°C
 Regulation accuracy: ± 0.5°C
 External temperature sensor: NTC 10K
 Communication: RS485
 Dimensions: 86 x 86 x 13.3 mm
 Weight: 270 g
 Degree of protection (housing): IP 20
 Degree of protection (external sensor): IP 68

Fanspeed controller HC

designed to change the single-phase fan's speed voltage controlled in industrial supply and heating systems. It is available in several versions. The selection of the appropriate model depends on the number of the devices that have to be connected to the to one regulator – the total intensity of the connected devices cannot exceed the maximum current flow of the regulator.



5 control levels: 80-105-135-170-230 V
 Voltage/ Frequency: 230 V AC / 50 – 60 Hz
 Maximum current output (depending on model):
 1.2 A, 3 A, 5 A, 7 A, 14 A
 Protection: thermal switch
 Weight(depending on model):
 1.45 kg, 2.5 kg, 4.5 kg, 5.5 kg or 10.5 kg
 Degree of protection: IP 54

Two-way valve with actuator 3/4"

is used to automatically regulate the flow of the heating medium.

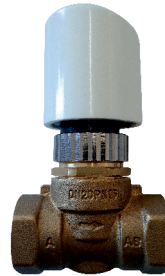

Voltage / Frequency: 230 V AC / 50 – 60 Hz
 Power consumption: 2 VA
 Kvs coefficient: 6.3 m³/h
 Stroke: 3 mm
 Operating condition of actuator: -5°C - 60°C
 Running time: 3 - 5 min
 Degree of protection: IP 54

Three-way valve with actuator HC 3/4"

is used to automatically regulate the flow of the heating medium.



Power supply/ Frequency: 230 V AC / 50 – 60 Hz
 Power consumption: 7 VA
 Kvs coefficient: 6.5 m³/h
 Operating condition of actuator: 0 - 60°C
 Running time (motor): 18 s
 Running time (return spring): 5 s
 Degree of protection: IP 20

Relay Module RM-16A

allows to connect a receiver with higher current consumption than permissible current load of connected regulator.



Power supply/ Frequency : 230 V AC / 50 – 60 Hz
 Maximum rated current: 16 A
 Input: NO/COM
 Input: SL Connection of a regulator with the voltage relay 230 V
 Dimension: 47 x 47 x 20 mm

Manual thermostat HC

controls operation of the heater. Switches the unit off automatically when the set temperature is reached.



Power supply/ Frequency: 230 V AC / 50 – 60 Hz
 Maximum rated current: 3 A
 Operating temperature: 0 - 40°C
 Temperature control range: 10 - 30°C
 Control accuracy: < 1°C
 Degree of casing's protection: IP 30

COOPERATION OF CONTROLLERS WITH EQUIPEMENT

Model	HC3S	HMI	HC 1.2 A	HC 3 A	HC 5 A	HC 7 A	HC 14 A	RM- 16 A
S1-3S	7	12	3	7	12	17	35	40
S2-3S	5	8	2	5	8	12	24	27
S3-3S	5	8	2	5	8	12	24	27
S4-3S	3	5	1	3	5	8	16	19

7. CONNECTION SCHEMES

LEGEND:

1. Power
2. Main switch, overcurrent circuit breaker*
3. Air water heater S-3S
4. 3-stage speed controllers with thermostat
 - A-work in continuous mode
 - B-operation in thermostatic mode
5. Valve with actuator HC 3/4 "
6. Fan speed controller HC
7. Manual thermostat HC
8. Programmable controller HMI
9. Relay module RM-16A
10. External temperature sensor

* main switch and safety fuses are not included in the set

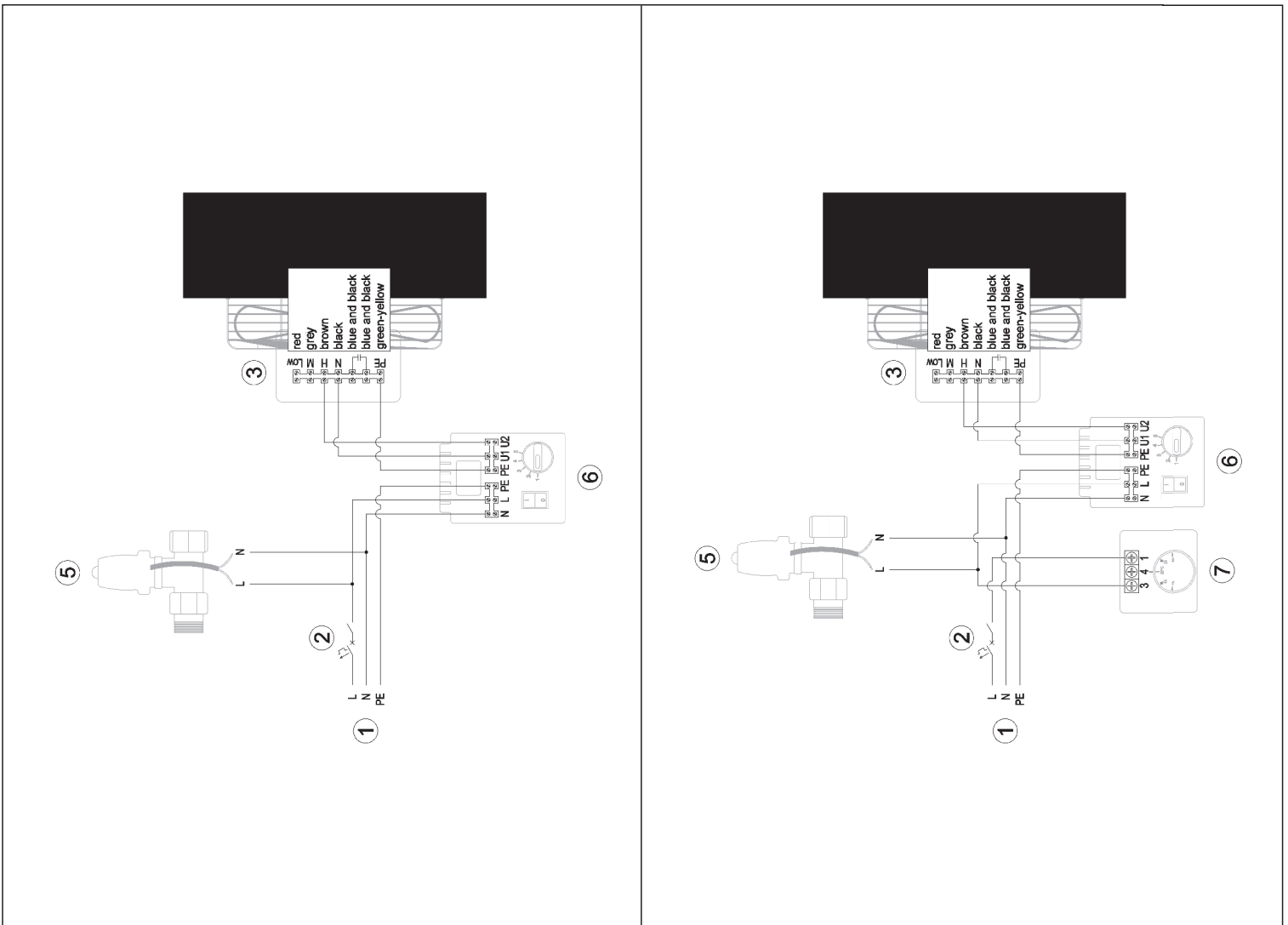

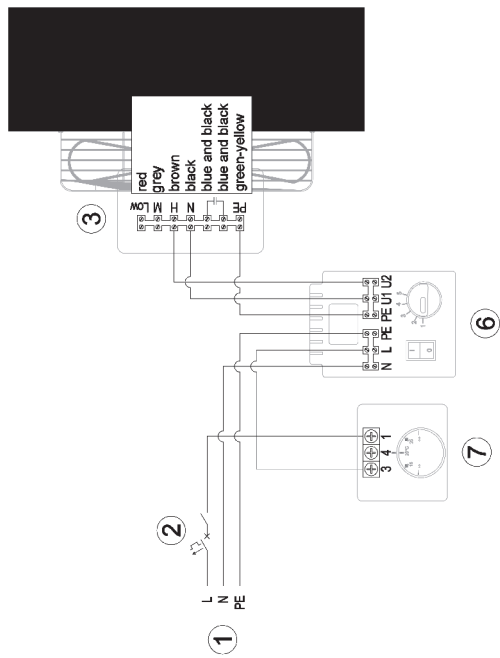
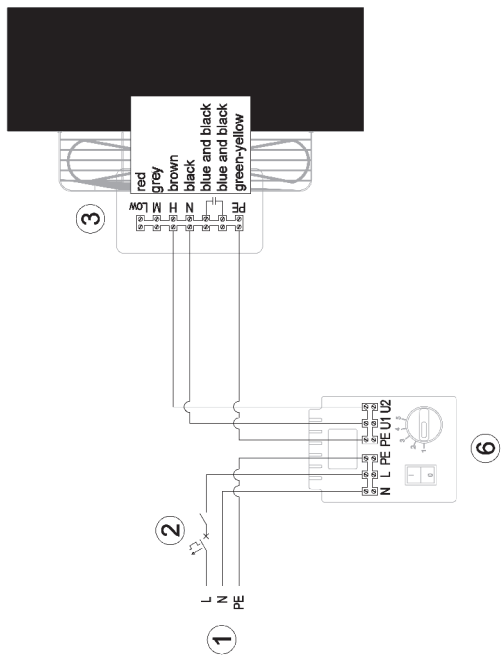

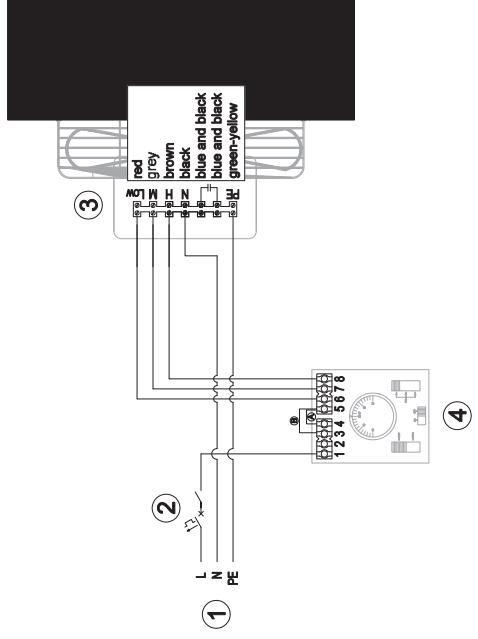
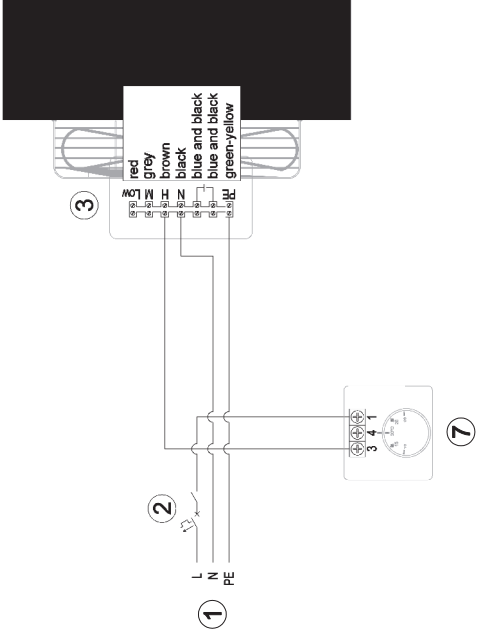
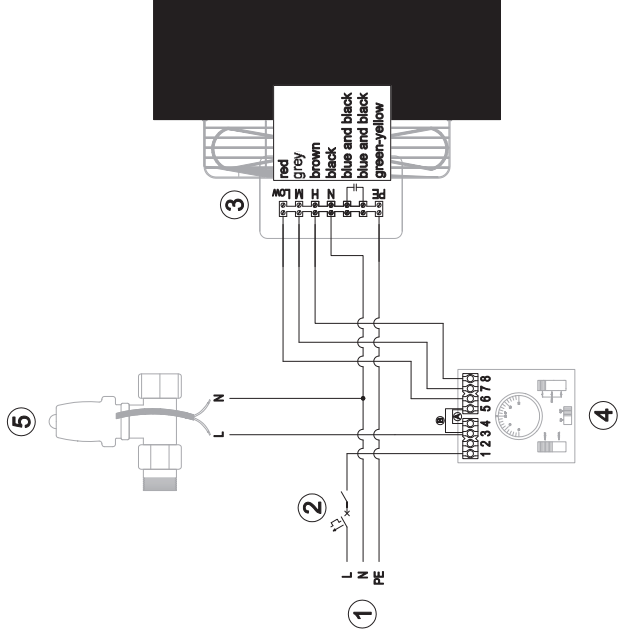
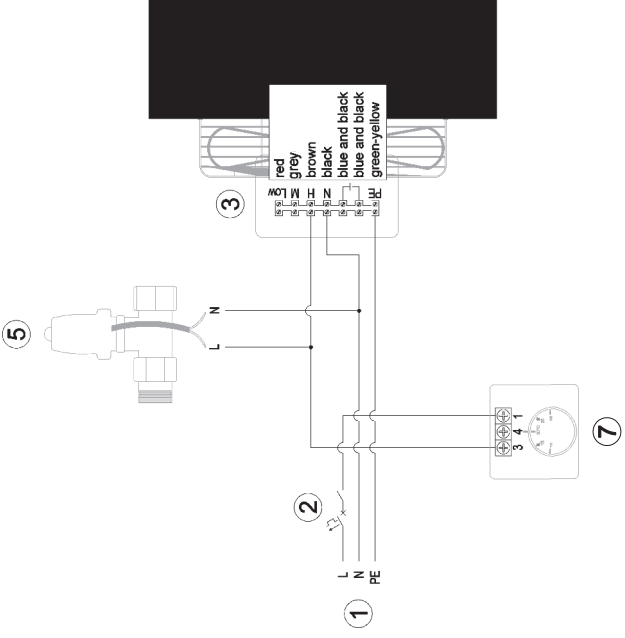

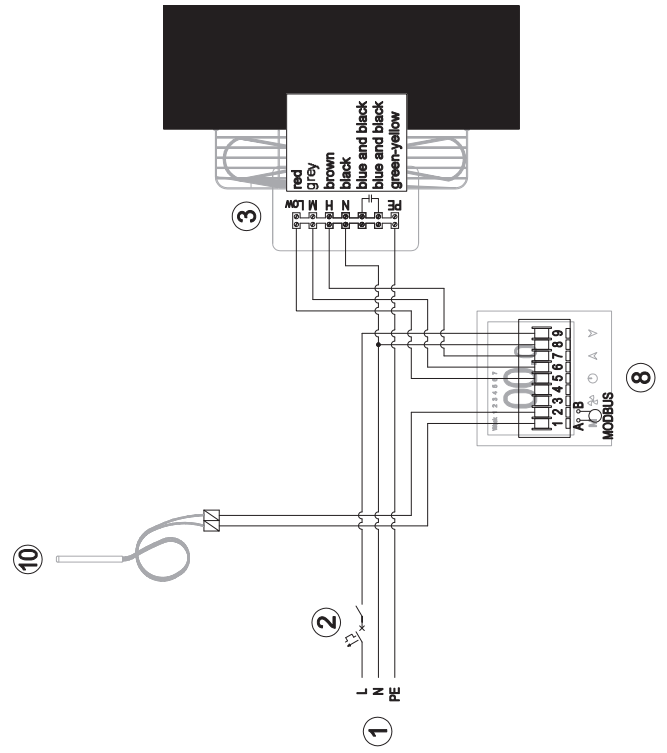
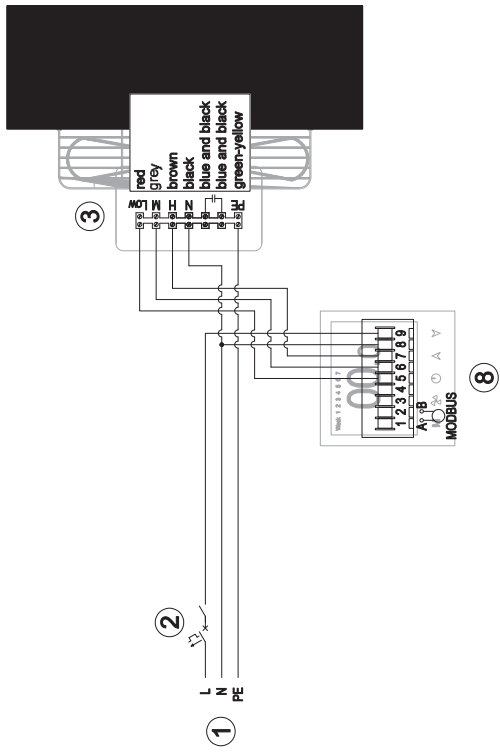
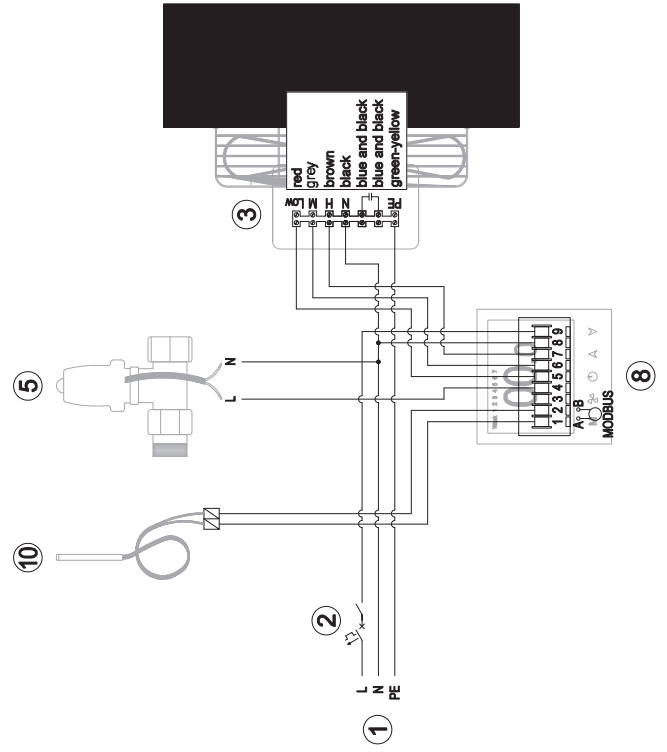
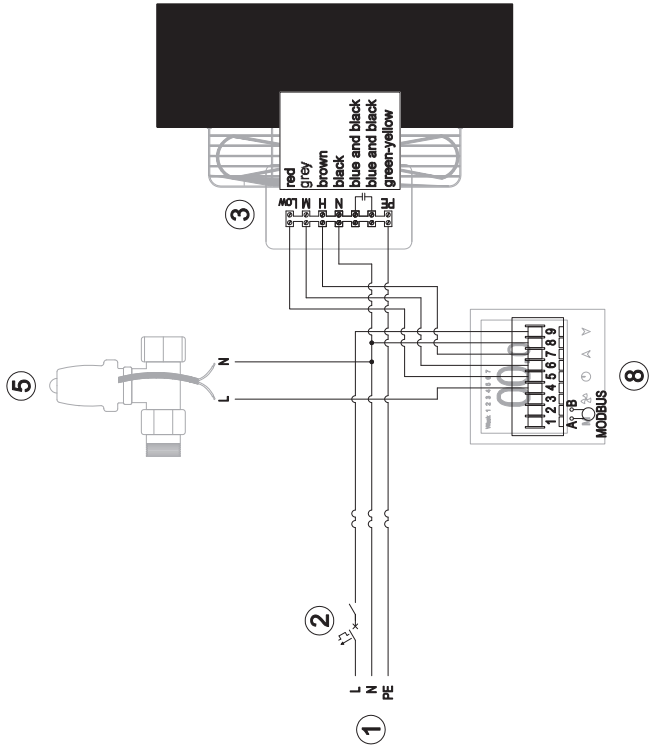

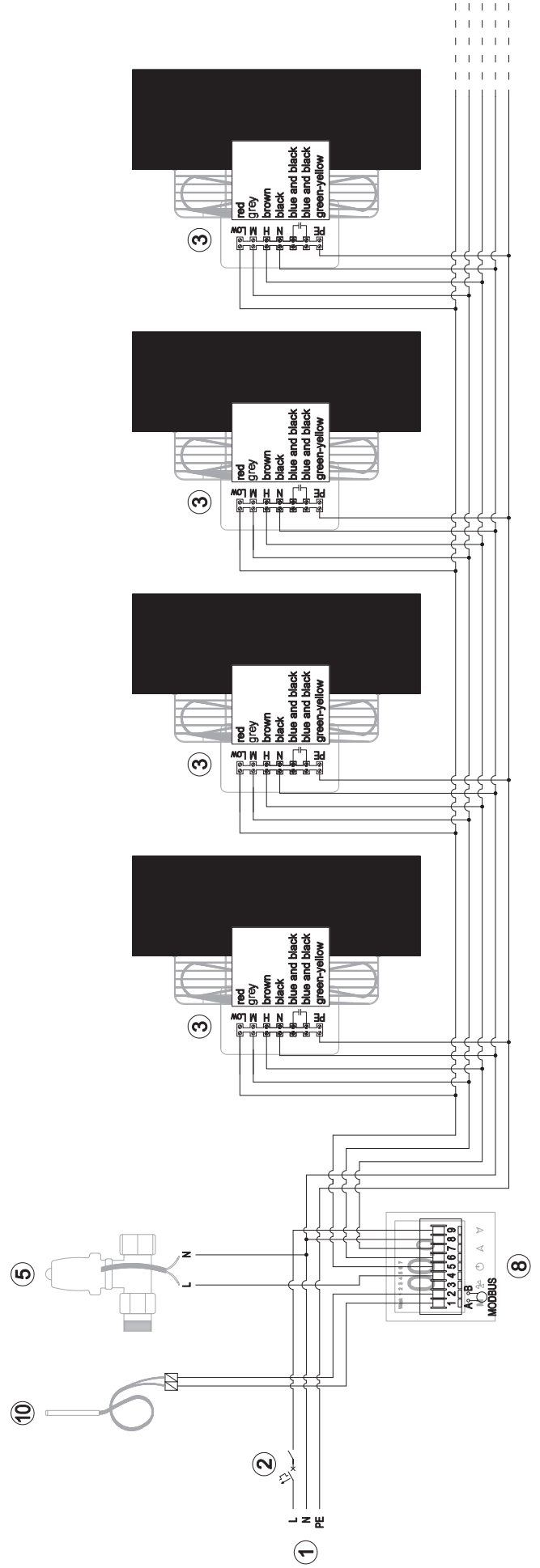
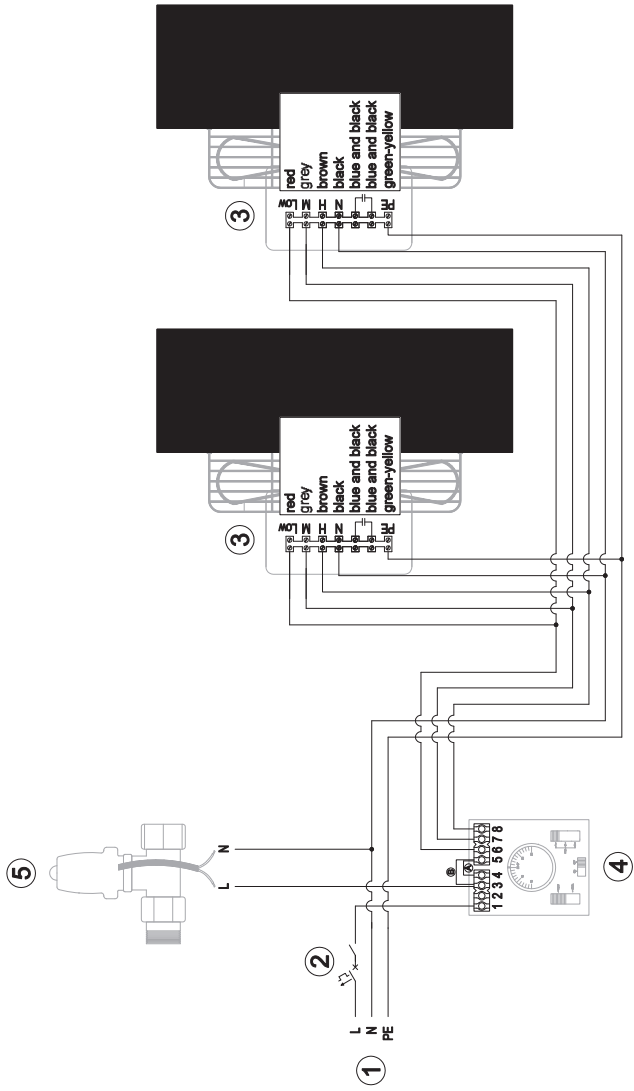

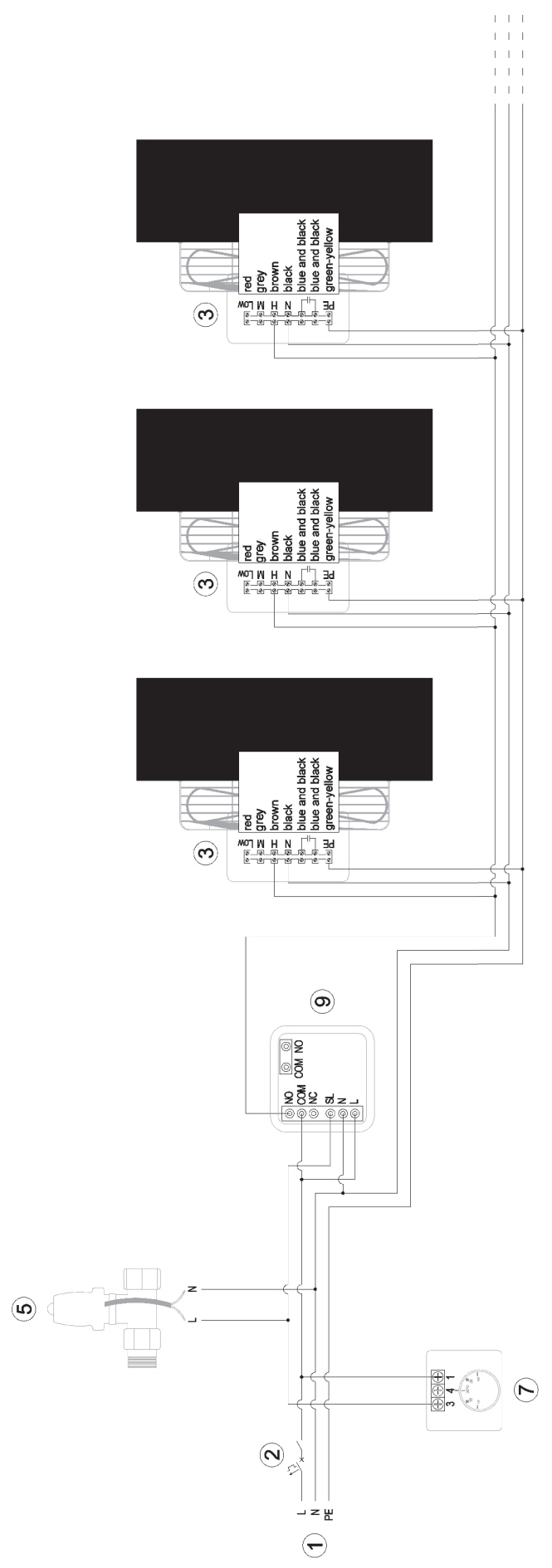
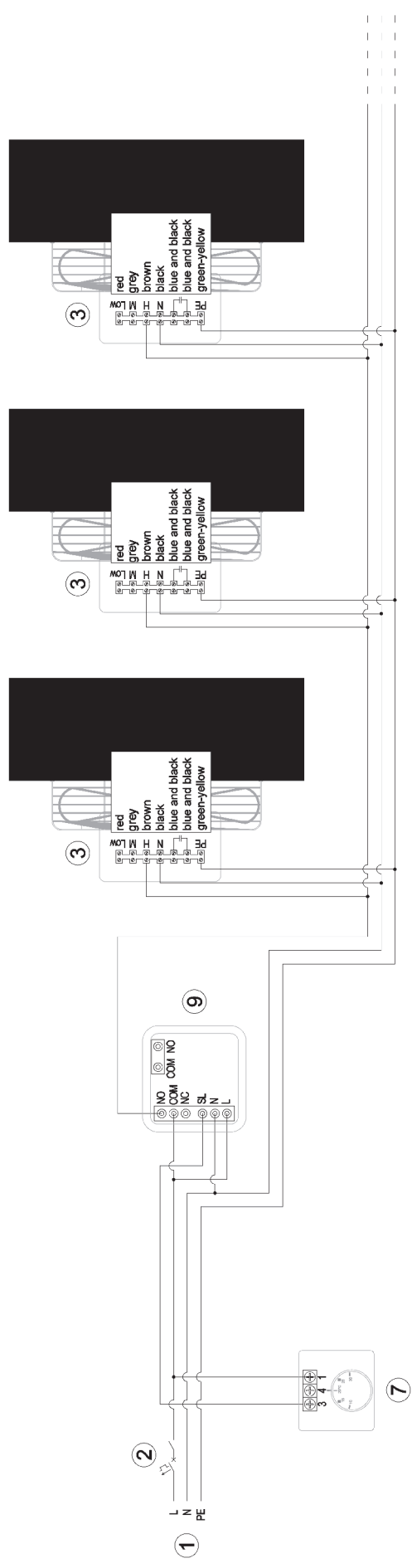

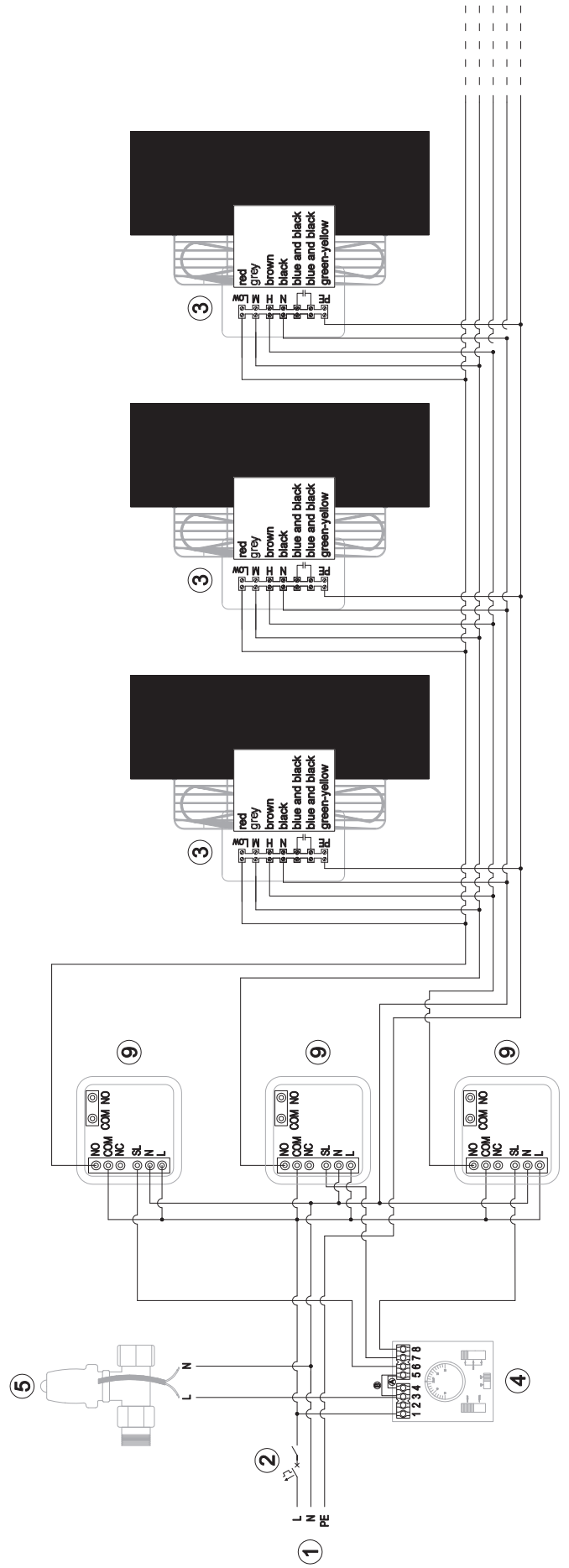
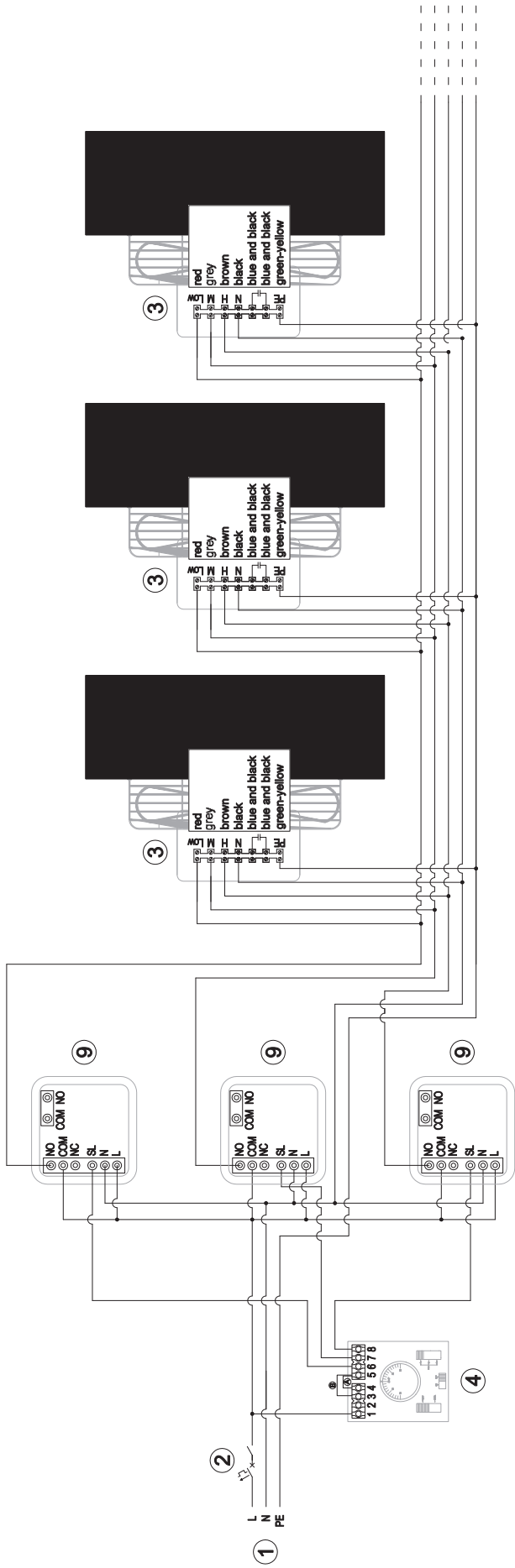

8. TERMS OF WARRANTY

I. Producer Reventon Group Sp. z o.o. [Ltd.] grants the buyer a 24-month warranty period for the following devices:

- air water heater S1-3S
- air water heater S2-3S
- air water heater S3-3S
- air water heater S4-3S

II. The terms of warranty are valid from purchasing the device (i.e. invoice / another confirming document issue date) but not longer than 30 months from leaving the producer's warehouse.

III. To obtain the service it is needed to provide or send to the producer scans of the warranty card with stamp of installation company, document confirming the purchase (eg. like copy of the invoice) and correctly filled the warranty form.

IV. The producer is committed to consider the claim within 14 working days since the date of reporting (i. e. day when documents given in point III are provided).

V. In the exceptional cases, the producer reserves the right to extend the time limit for examination of warranty, especially if the defect is not permanent and its determination requires a longer period of time. The extension must be notified by the producer before the end of the 14th working day.

VI. Under the guarantee the producer provides a repairment, replacement or refund for the defective device within a specified time limit.

VII. Warranty does not cover the parts of the device subject to normal maintenance and the following cases:

a) mechanical damage of the product

b) defects and damages through:

- improper storage or transport
- improper or non-compliant use and maintenance (i. e. inconsistent with the manual)
- using the device in the improper conditions (too high humidity, too high or too low temperature, impact of the surrounding, sun etc.)
- unauthorized (by the user or other unauthorized persons) repairs, modifications or construction changes
- connecting equipment inconsistent with the technical documentation
- connecting additional equipment, which is not recommended by the producer
- improper power supply

c) elements which wear and tear such as discolor of the housing

If there is any of the above, claimant will be charged for transport and /or repairs.

VIII. Any changes in the Warranty Terms, improper use of the product (careless handling, exposure to liquids, moisture, corrosion), as well as traces of self-repairing (non by the Reventon Group) or alterations cause, the warranty is not valid.

IX. Not following to any of warranty regulations makes the warranty not valid.

X. All correspondence, returns, complains should be send to the following address: Reventon Group Sp. z o.o. [Ltd.], 556 Wyzwolenia Street, 43-340 Kozy, Poland or email address: serwis@reventongroup.eu.

The producer reserves the rights to make changes to the technical documentation without previous notice.

Warranty card

Factory number of the device:	Address and place of assembly:
Stamp and signature of the installation company:	

Warranty form

The company reporting the complaint:	Date of assembly:	Address and place of assembly the device:
The company installing the device:	Date and circumstances of noticing the defect:	
	Factory number of the device:	Date of declaration the complaint:
Description of the defect:		
Contact Name and Surname, telephone number/ e-mail address:		

Service card

Date of declaration the complaint:	Description of the repair:	Service stamp:
Date of repair:		



reventon
INDUSTRIAL SOLUTIONS

Reventon Group Sp. z o.o. [Ltd.], 556 Wyzwolenia Street, 43-340 Kozy, Poland, www.reventongroup.eu